

Overview

HP sets the standard for performance and value in the enterprise with the Rack 10000 Series family. This enterprise-class rack cabinet system combines next-generation structural integrity and ease of use capabilities to deliver industry-leading performance. Ideal for onsite assembly of rack mounted ProLiant, Alpha, and Tandem servers, workstations, networking, and StorageWorks products, the 10000 Rack Series of cabinets, complement and protect your customer's investment in technology. Specifically designed to ensure outstanding performance and seamless integration throughout the entire enterprise, the Rack 10000 could easily be the last family of racks that you ever have to buy.

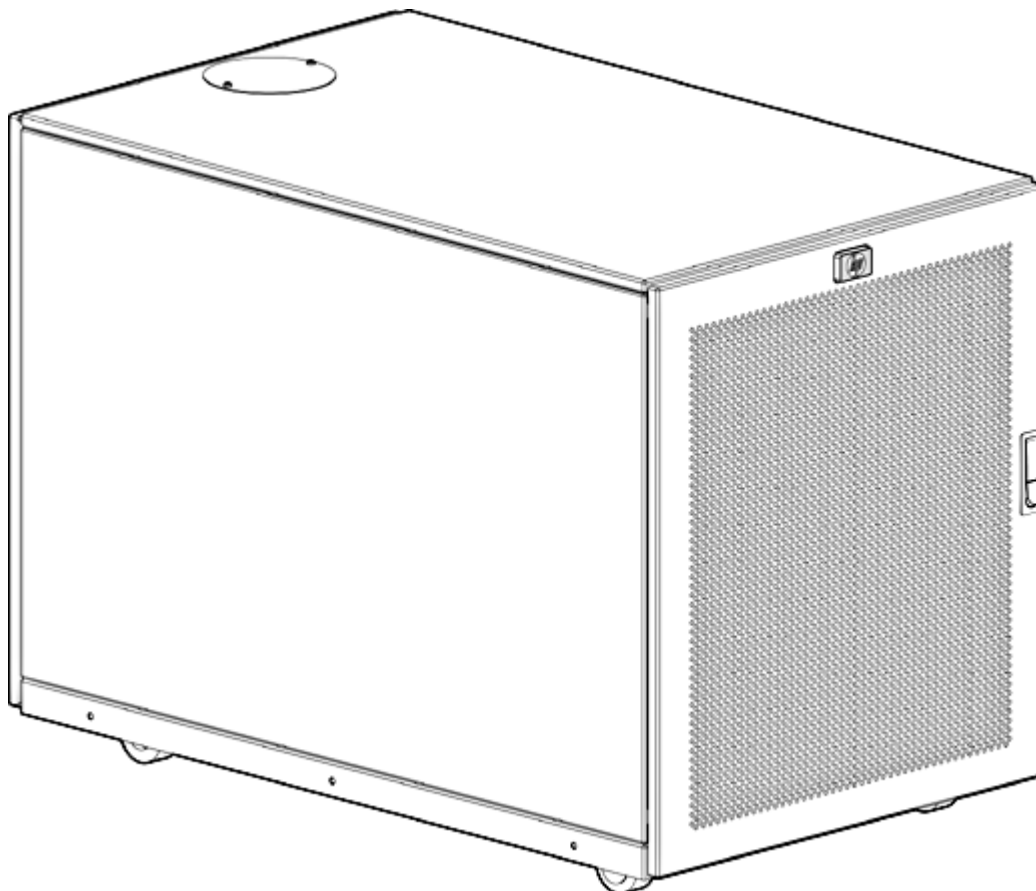

HP S101614, 14U Rack

What's New

- The S10614 is the remaining rack from the 10000 Series rack, the rest of the racks models, 10636, 10642, 10842, 10647 are now being offered as G2 products

Overview

At a Glance

- 14U height
 - Thermal integrity
 - Security provisions
 - Shock pallet for factory CTO and dynamic loads
 - Sidepanels included
 - Heavy duty casters
 - Powerful 3 year Warranty (3-0-0)
-

Models

S10614 (14U) Rack Cabinet - Shock Pallet

292302-B22

Standard Features

Industry Standard Support All products are 19 inch RETMA standard and will support select third-party equipment
Extensive evaluation, and testing across all critical platforms

Key HP Infrastructure Rack components

Innovative Breakthroughs

- HP is the only IT rack provider to offer a complete line of options and accessories that are designed to support HP products.
 - HP's reputation for providing the highest quality products throughout the entire enterprise is based on our strategic partnerships, extensive product research, product development and product testing processes.
 - All rack sizes (including the S10614 rack are configurable at HP CTO (Configure to Order) facilities.
-

The HP Rack System

All HP rack-mountable products are designed to fit our industry-standard 19-inch wide racks. HP offers several racks to meet your system needs.

Racks and rack-mountable components are typically described using "U" measurements. One "U" is 1.75" (44.45 mm) high.

This sturdy, industrial-strength rack series offers the following features:

- Universal - Accommodates all HP equipment (ProLiant, Alpha, StorageWorks, UPS, PDU) in addition to select third party equipment
- Design - Perforated front and back doors which allows for high air flow and cooling up to 65% open; U marking front and sides of rails to ease component installation; increased cable management features

NOTE: Side Panels ship standard on the S10614 models.

Product Features

HP Rack 10000 Series Key Benefits (Universal Rack)

The HP Rack 10000 Series offers protection, price, performance and quality. The following are a few of the many benefits that come standard:

- **Unique Frame and Rail Design** - enables fast assembly, easy mounting and outstanding structural integrity. Equipment installation effort is dramatically reduced because the vertical mounting system was specifically designed to minimize the time required to install HP products, and can be used with many other non-HP products as well. U markings on the front and sides of rails make it easy to align parts when installing equipment. Cut outs in the rails also allows for cabling between racks.
- **Thermal Integrity** - Front to back natural convection cooling is greatly enhanced by the innovative multi-angled design of the front door. For additional heat removal, an optional roof mounted fan kit can be easily installed.*
- **Security Provisions** - Front and rear doors are lockable, which provides the necessary level of security to prevent unauthorized entry. Side panels are also lockable* allowing for your entire rack row to be secure.
- **Flexibility** - Outstanding cable management features make it easy to develop effective solutions and easy to maintain. Cable egresses in the top of the rack allow for ample room for routing cables outside of the rack. The split rear doors* give ample access to rack mounted equipment without blocking rack rows while the removable panel gives added flexibility for cable routing. Velcro straps are provided in the hardware bag for clean cable bundling within the rack.

* Except S10614. The side panels and roof are not removable and cannot be bayed. The S10614 features one back door (not split).

Low Total Cost of Ownership

Exclusive product options and accessories that optimize rack space utilization

- TFT7210R - 1U Flat panel rack-mount monitor
- 0U and 1U mounting kits for options such as the new Modular Power Distribution Units (mPDU)
- Cost-saving Server Console Switches (KVM) with multiple mounting options
- TFT7600 Rackmount Keyboard and Monitor
- Integrated Keyboard and Drawer
- Highest levels of system management, performance, construction and compatibility

Investment Protection

- Investment security across all mainstream ProLiant server and storage products.
- Well-designed and crafted options provide unlimited flexibility in growing or adapting the 10000 series of rack cabinets to specific requirements and needs.
- Advanced product integration and quality provides high system reliability

Simplified Management

- Unique frame and rail design minimizes time necessary to install products in rack cabinet
- Product selection:
 - 47U @ 2.3 M
 - 42U @ 2.0 M
 - 36U @ 1.7 M
 - 22U @ 1.1 M
 - 14U @ 0.7 M
- All mainstream ProLiant server and storage products are easily managed with our seamless enterprise integration process

Product Features

Industry-leading Breakthroughs

- Exclusive 42U in a two-meter rack cabinet height for easy door clearance
- The only company to provide a complete line of options and accessories that are designed to support HP products
- Special 14U rack designed specifically for remote site deployments.
- 2000 lb dynamic load capacity for the S10642

Service and Support, HP Care Pack, and Warranty Information

Warranty

Three year warranty, parts only (3-0-0).

NOTE: Certain restrictions and exclusions apply. Consult the HP Customer Support Center for details.

Care Pack services provide a range of life cycle support options that let you choose the service levels that meet your business requirements, from basic to mission-critical.

A full range of HP Care Pack hardware and software services are available including:

- Installation and start up
- Education courses
- Extended onsite hardware coverage hours from same business day 13 hours, 5 day to 24 hours, 7 days call window with options including 4-hour response or 6-hour Call To Repair
- Comprehensive range of software technical support for Microsoft, Linux, ProLiant Essentials and VMware-based IT solutions helping to deliver high level of application availability. Response times range from 30 mins for critical problems to 2 hours.
- System Management, Performance Services and Mission Critical Support Solution

NOTE: For more information on HP Care Pack services, contact any of our worldwide sales offices or resellers or visit our worldwide Web site on the internet at: <http://www.hp.com/hps/carepack>

NOTE: For more complete information on HP Services offerings, customers and resellers, please visit us at: <http://www.hp.com/hps>

NOTE: Additional information regarding worldwide limited warranty and technical support is available at: <http://h18004.www1.hp.com/products/servers/platforms/warranty/index.html>

NOTE: For additional information on Server Services, Rack and Power Options, please visit: <http://h20219.www2.hp.com/services/cache/111072-0-0-225-121.html>

NOTE: The information contained herein is subject to change without notice and is provided "as is" without warranty of any kind.

NOTE: The warranties for HP products and services are set forth in the express limited warranty statements accompanying such products and services.

NOTE: Nothing herein should be construed as constituting an additional warranty. HP shall not be liable for technical or editorial errors or omissions contained herein.

Rack Options

Several options allow for quick and easy expansion of the HP Rack 10000 Series racks to create a custom solution.

NOTE: This is only a sampling of the many HP Rack options available. See the HP rack products Web site for more complete information at <http://www.hp.com/products/rackoptions>. Contact your nearest HP Authorized Reseller or Service Provider for information about ordering HP parts. In the United States, HP can make arrangements to have your rack system installed by qualified Guaranteed Service Providers. This installation service covers the entire hardware installation sequence, from unpacking the components to routing cabling and running a test of the system.

HP Rack Light Kit	110V/220V Rack Light Kit NOTE: Supports HP Rack 10000 Series only. This neon light kit is mounted on the rack roof and used to provide light to the rear section of the rack.	361589-B21
HP Monitored Power Distribution Unit	<p>HP Monitored Power Distribution Unit - Full Rack Version</p> <p>HP 17.3 kVA S2324 Monitored PDU- dual input, 3Ø, 24A (NA/JPN) AF503A</p> <p>HP 8.6 kVA S1324 Monitored PDU- single input, 3Ø, 24A (NA/JPN) AF504A</p> <p>HP 16.6 kVA S2140 Monitored PDU- dual input, 1Ø, 40A (NA/JPN) AF505A</p> <p>HP 8.3 S1140 Monitored PDU- single input, 1Ø, 40A (NA/JPN) AF506A</p> <p>HP 22.1 kVA S2316 Monitored PDU- dual input, 3Ø, 16A (INTL) AF507A</p> <p>HP 11 kVA S1316 Monitored PDU- single input, 3Ø, 16A (INTL) AF508A</p> <p>HP 14.7 kVA S2132 Monitored PDU- dual input, 1Ø, 32A (INTL) AF509A</p> <p>HP 7.3 kVA S1132 Monitored PDU- single input, 1Ø, 32A (INTL) AF510A</p> <p>NOTE: "Ø" = number of electrical phases at input.</p> <p>HP Monitored Power Distribution Unit - Half Rack Version</p> <p>HP 17.3 kVA S348 Monitored PDU- single input, 3Ø, 48A (NA/JPN) AF916A</p> <p>HP 22 kVA S332 Monitored PDU- single input, 3Ø, 32A (INTL) AF917A</p> <p>HP 4.9 kVA S124 Monitored PDU- single input, 1Ø, 24A (NA/JPN) AF914A</p> <p>HP 7.3 kVA S132 Monitored PDU- single input, 1Ø, 32A (INTL) AF915A</p> <p>NOTE: "Ø" = number of electrical phases at input.</p>	
HP 1x4 USB/PS2 KVM Switch	<p>HP 1x4 Server Console Switch AF611A</p> <p>HP PS2 Server Console Cable, 6 foot, 2-Pack AF612A</p> <p>HP USB Server Console Cable, 6 foot, 2-Pack AF613A</p> <p>NOTE: USB cable required for supporting USB peripherals.</p>	
Grounding Kit	9000/10000 Grounding Kit 260457-B21 NOTE: The Grounding Option Kit makes it possible to completely integrate grounding in HP racks.	
Cable Management	Cable Management "D" Rings Kit (10 pack) 168233-B21 NOTE: This kit consists of 10 "D" rings that can be used in addition to the rings that ship standard in the 10000 series and 10000 G2 series racks for cable management.	

Rack Options

Blanking Panel Kit (Carbon Graphite)	1U Universal Blanking Panel kit (10 panels)	AF070A
	1U Universal Blanking Panel kit (100 panels)	AF071A

NOTE: OD1 will appear after the above selected part numbers on your sales order if factory integration is indicated.

NOTE: The blanking panels are made from high grade molded plastic, and are designed to be installed without tools. The use of blanking panels is recommended to ensure proper airflow.

HP Locking Drawer	HP 2U Universal Locking Drawer (WW)	361591-B21
--------------------------	-------------------------------------	------------

NOTE: OD1 will appear after the above selected part numbers on your sales order if factory integration is indicated.

NOTE: This product mounts on HP 10000 Series and 10000 G2 series racks with sliding rails and is used to store CD's, Instruction manuals, tools, and any other item that is frequently used at the rack. Drawer includes lock.

Service and Support Offerings (HP Care Pack Services)	Hardware Installation (Electronic)	U2871E
---	------------------------------------	--------

Technical Specifications

S10614 Rack Physical Characteristics

Dimensions (HxDxW)	Total Cabinet Area	28.5 x 39.69 x 23.6 in (72.4 x 100 x 60 cm)
	Shipping (with packaging materials)	34 x 44x 30.5 in (86.36 x 111.82 x 77.5 cm)
Weight	Operating	135 lb (61 kg)
	Shipping	190 lb (86.18 kg)
Load	Static	600 lb (270 kg)
	Dynamic	500 lb (227 kg)
Color	Doors	Graphite Metallic
	Frame	Carbon

Environment-friendly Products and Approach	End-of-life Management and Recycling	Hewlett-Packard offers end-of-life HP product return, trade-in, and recycling programs in many geographic areas. For trade-in information, please go to: http://www.hp.com/go/green . To recycle your product, please go to: http://www.hp.com/go/green or contact your nearest HP sales office. Products returned to HP will be recycled, recovered or disposed of in a responsible manner.
---	---	--

The EU WEEE directive (2002/95/EC) requires manufacturers to provide treatment information for each product type for use by treatment facilities. This information (product disassembly instructions) is posted on the Hewlett Packard web site at: <http://www.hp.com/go/green>. These instructions may be used by recyclers and other WEEE treatment facilities as well as HP OEM customers who integrate and re-sell HP equipment.

© Copyright 2008 Hewlett-Packard Development Company, L.P.

The information contained herein is subject to change without notice.

The only warranties for HP products and services are set forth in the express warranty statements accompanying such products and services. Nothing herein should be construed as constituting an additional warranty. HP shall not be liable for technical or editorial errors or omissions contained herein.