

Overview

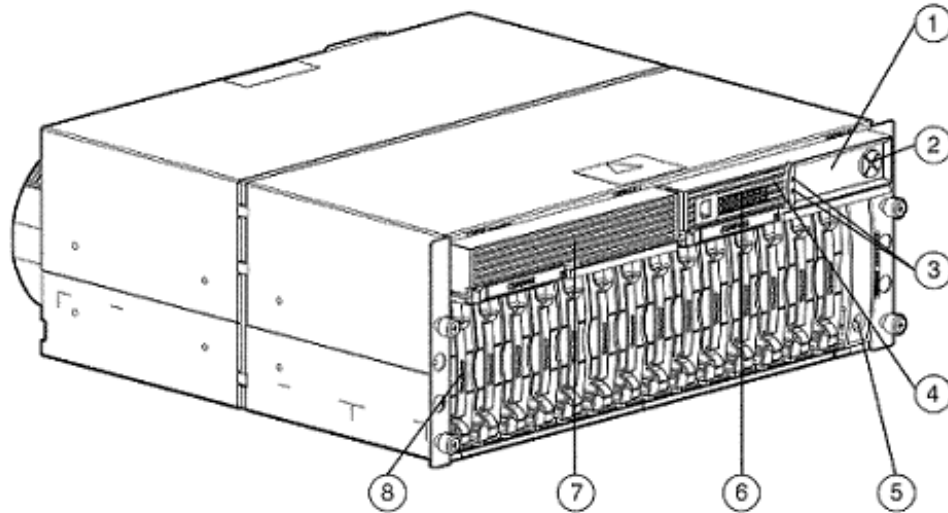

- 1. Display
- 2. Display Buttons
- 3. Display Indicators
- 4. Modular Smart Array Controller

- 5. Power Switch
- 6. Status Indicators
- 7. Redundant Controller Slot Blank
- 8. Drive Bay(s)

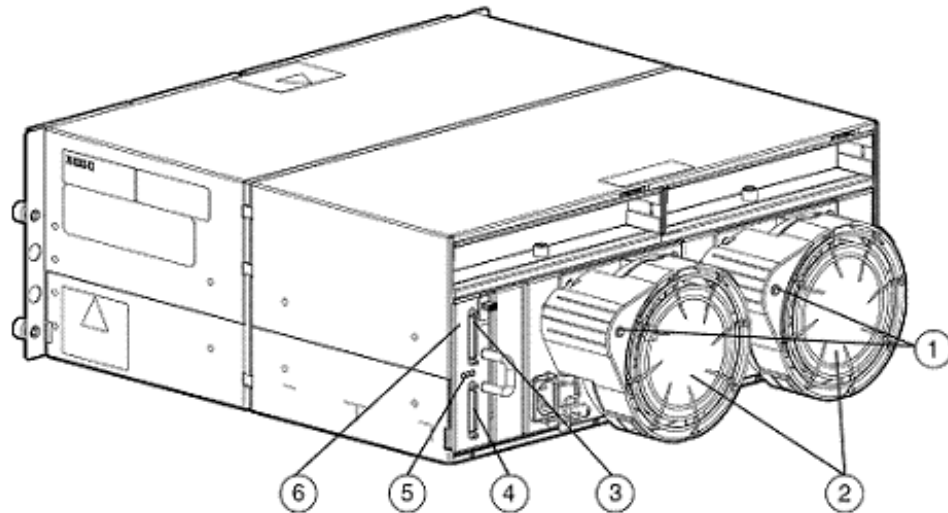

- 1. Power Supply/Blower Indicators
- 2. Power Supply/Blower Assemblies
- 3. SCSI Port A

- 4. SCSI Port B
- 5. SCSI I/O Indicators
- 6. SCSI I/O with Integrated Environmental Monitoring Unit (EMU)

Overview

What's New

- End-to-end Ultra320 SCSI technology
 - Support for 4-node clustering
 - 256MB battery-backed cache
 - New Rapid Drive Rebuild technology - increases RAID 5 and RAID ADG drive rebuilds
-

At A Glance

- Total storage capacity of 4.2TB (14 HP Universal disk drives of 300 GB)
- 4-node high availability clustering for Linux (LifeKeeper and Serviceguard) and NetWare
- 2-node high availability clustering for Windows, Linux, and NetWare
- Shared storage for up to 4 ProLiant servers
- Boot from storage - move all disks to external storage for best capacity utilization
- Redundant capable Smart Array Controllers
- Multipath connectivity option with load balancing
- Redundant power supplies and fans standard
- Convertible to HP StorageWorks Modular Smart Array 1000
- 3 year warranty with next day on site service
- Protected by HP Services and a worldwide network of resellers and service providers. Certain restrictions and exclusions apply. Pre-failure notification on processors, memory and SCSI hard drives.

Standard Features

Modular Smart Array Family

The HP StorageWorks Modular Smart Array family delivers simple, affordable storage technology to meet today's demanding and growing IT needs. These storage solutions offer the best price/performance and best price/availability features for direct attach environments, small clusters, workgroups and entry-level SAN environments. Each solution is designed to be easy to deploy, secure, reduce management costs, while driving rapid return on investment.

Modular Smart Array 500 G2

- High performance Modular Smart Array controller(s) with LCD for system status messages.
- 256-MB Battery Backed Cache, upgradeable to 512 MB maximum.
- Optional redundant Modular Smart Array controller.
- 4.2U rack mount chassis combining both the controller and disk shelf.
- End-to-end Ultra320 SCSI - Host interface, back panel and drive interconnect.
- Selective Storage Presentation (SSP) for storage sharing with multiple servers (LUN Masking)
- 4.2TB capacities with support of 14 Ultra320, Ultra3 and Ultra2 HP Universal Drives.
- Redundant power supplies and fans are standard.
- RAID levels 0, 1, 1+0, 5, RAID ADG.
- Rapid Drive Rebuild technology accelerating RAID 5 and RAID ADG drive rebuild rates
- Optional MSA 4-Port I/O Module with Smart Array Multipath software
- Convertible to MSA 1000 for capacity expansion and increased host connections
- Remote configuration and monitoring via Array Configuration Utility & System Insight Manager.
- Qualified and certified for Windows, Linux and NetWare clustering
- Support for ProLiant servers (see Server Compatibility on page 14 or <http://www.hp.com/go/msa> for latest compatibility).

Product Highlights

Modular Smart Array 500 G2 Highlights

High Levels of Performance, Data Protection and Functionality

- **High Availability** – supports a broad range of clustering options for Microsoft Windows Server, Linux Server and Novell NetWare environments.
- **High Performance** – 14,000 IO/s in a 2 host, 14 drive environment. Double the workload performance of 1st generation MSA500.
- **Storage Capacity** – The Modular Smart Array 500 G2 cabinet supports up to fourteen 1" Universal hard drives, for a maximum of 4.2TB of shared storage capacity using HP 300GB Ultra320 SCSI Universal 1" hard drives.
- **Data Protection** – Modular Smart Array 500 G2 is designed for a high level of data protection. It includes redundant controllers (optional), redundant fans and power supplies (standard) multiple I/O path capability with Smart Array Multipath software option, battery-backed cache and RAID ADG (standard).
- **Storage Manageability** – The Smart Array Controllers feature familiar configuration and management tools such as HP Smart Array Configuration Utility and Insight Manager. Online Management Features: Online Capacity Expansion (single path only), Online RAID Level Migration, Online Stripe Size Migration, Online Spares (Global), User Selectable Read/Write cache, User Selectable Expand and Rebuild Priority.
- **Choice of Computing Platform** – The Modular Smart Array 500 G2 is designed and qualified for ProLiant servers.
- **Advanced Data Guarding (RAID ADG) Fault Tolerance** – This is the highest level of RAID fault tolerance. It allocates two sets of parity data across drives and allows simultaneous write operations. This level of fault tolerance can withstand two simultaneous drive failures without downtime or data loss.

DtS (DAS to SAN) Technology

The Smart Array architecture provides a quick and easy way to migrate from the Modular Smart Array 500 G2 to the Modular Storage Array 1000 (MSA 1000) for additional scalability.

In order to convert the Modular Smart Array 500 G2 to a FC SAN, simply remove the Modular Smart Array Controller(s) and replace them with StorageWorks MSA1000 Controller(s) (218231-B22) and add FC I/O module(s) (218960-B21) or FC Switch(es) (288247-B21). By doing so the user can save their investment in the basic chassis and all their drives. A full back-up and restore IS NOW REQUIRED when migrating from an MSA500 G2 to an MSA1000. Prior to the current shipping firmware the customer was not dependent on doing a restore to move the data, now it does require a restore.

Product Highlights

Low Total Cost of Ownership

The modular, scalable design of the Modular Smart Array 500 provides an extremely flexible platform. You can buy what you need today and purchase additional capacity and performance as your data storage needs grow, instead of making a large up-front investment. Additional drives, controllers, and cache can be easily added as your needs dictate.

- **Storage Consolidation** – Improve storage utilization and lower storage management cost through moving internal storage to the Modular Smart Array 500 G2.
- **Universal Hard Drive** – Since the Modular Smart Array 500 G2 supports HP Universal SCSI drives, your investment in disk drives is protected and cost is minimized as you add new drives. Sharing of a common universal drive form factor between your server and storage can significantly reduce needs for hardware and spare inventory, and offer overall reduction in storage management and business costs.
- **Pre-Failure Warranty** – Drives installed in a Modular Smart Array 500 G2 and monitored under Insight Manager are supported by a Pre-Failure (replacement) Warranty. Pre-Failure Warranty allows for the replacement of designated drives in Modular Smart Array 500 G2 before they actually fail when using Insight Manager on ProLiant servers. **NOTE: Some operating systems may not support all of these features.**
- **Integrated Configuration and Management Tools** – The Modular Smart Array 500 G2 utilizes the standard, integrated set of Smart Array management and utility software. These tools consistently lower the cost of ownership by reducing training and technical expertise necessary to install and maintain HP server storage.

Modular Smart Array 500 G2 Components

Modular Smart Array 500 G2 Enclosure The 4U array houses up to fourteen 1" Universal hot pluggable Ultra320, Ultra3 and/or Ultra2 drives. Each Modular Smart Array 500 G2 includes the following standard components: Modular Smart Array 500 G2 Controller, 2-port Ultra320 SCSI I/O Module, dual hot pluggable fans/power supplies, two power cables, two Ultra320 SCSI host adapters (SA-642), two VHDCI SCSI cables and a crossover Ethernet cable for clustering.

Modular Smart Array 500 G2 Controller The Modular Smart Array 500 G2 Controller is an integrated RAID controller with an integrated LCD/LED status display and 256-MB read/write battery-backed cache (expandable to 512MB per controller). One Modular Smart Array 500 G2 Controller is included with the Modular Smart Array 500 G2; the redundant Modular Smart Array 500 G2 Controller is an option.

Modular Smart Array 500 G2 HBA The Modular Smart Array 500 G2 HBA is a Smart Array 642 that offers two Ultra320 SCSI channels. An external channel for connectivity to the MSA500 G2 systems and an internal channel to provide RAID protection to Disk internal to the ProLiant server. The SA-642 is a 64-bit PCI-X card backward compatible with 64 bit PCI slots.

MSA500 G2 4-Port I/O Module with Smart Array Multipath The MSA500 G2 4-Port I/O Module option offers 4 Ultra320 ports to extend connectivity to up to 4 hosts or supporting multipath configurations. It frees captive storage capacity dedicated to a single server and increase storage utilization over internal server storage.

- 4-node cluster support with Serviceguard and LifeKeeper for Linux and Novell NetWare
 - Multipath support with load balancing enhances cluster fault tolerance by adding multiple paths from the host servers to the MSA500 G2. This provides an additional level of fault tolerance by adding redundancy to both the HBA in the host server as well as the SCSI cables connecting the host servers to the shared storage.
 - Attach up to four independent servers to the Modular Smart Array 500 G2. The storage capacity to each server is assigned with SSP (Shared Storage Presentation), a feature of the Array Configuration Utility. Using SSP and sharing storage among multiple host servers maximizes hard drive capacity utilization, and allows for additional hard drive capacity to be deployed (up to 14) with the volume extension and capacity expansion capabilities.
 - Mix 2-node cluster and shared storage configurations. This supported configuration allows for a 2-node cluster and 2 non-clustered servers to share the Modular Smart Array 500 G2 storage systems for maximum storage utilization.
-

Modular Smart Array 500 G2 Components

Smart Array Multipath Software

The Smart Array Multipath software included with the MSA500 G2 4-port I/O Module or the High Availability Kit provides an additional level of fault tolerance by adding redundancy and performance to both the HBA in the host server as well as the SCSI cables connecting the host servers to the shared storage. Smart Array Multipath software delivers dual path functionality and supports failover capabilities for redundant host bus adapters (HBAs). When an HBA failure occurs, the software moves the logical drives from the path of the failed HBA to the path of the redundant HBA located in the same server.

- Increase availability by protecting against connectivity (HBA) and cable failures and accidental pull-outs.
- Increase performance with Static LUN Balancing (Microsoft OS) enables the administrator to optimize I/O by assigning specific volumes to specific paths in the storage system. If one path fails the system moves volumes to the path for redundant HBA for I/O management.
- Increase performance with Static Load (read-only) Balancing (Linux OS) enables the HBAs to optimize I/O with dual paths to the same volumes in the storage system. If one HBA fails the system moves volumes to the path for the redundant HBA for I/O management.
- Supported Operating Systems: Windows Server 2003 Standard Edition, Windows Server 2003 Enterprise Edition; Windows 2000 Server; Windows 2000 Advanced Server; Red Hat Enterprise Linux 2.1, Red Hat Linux Advanced Server 2.1, Red Hat Enterprise Linux 3.0 (ES,AS), UnitedLinux 1.0, SuSE Linux Enterprise Server 8, 9.

Modular Smart Array 500 G2 Controller Management Features

- Online RAID Level Migration: allows for online post-configuration change to RAID level without destroying data or volume information.
- Online Capacity Expansion: allows for adding storage to an operational Modular Smart Array 500 G2 reducing expensive server downtime (single path configuration only).
- Online Volume Extension: allows for the capacity growth of existing logical volumes (single path configuration only).
- Logical Drive Capacity Extension: allows the user to increase the size of existing logical drives online under Windows and offline for other operating systems.
- Online Stripe Size Migration: allows changing stripe sizing of a logical drive.
- User selectable read/write cache size, allocate cache sizes.
- User selectable disk drive expand and rebuild priority with Rapid Drive Rebuild technology

Controller Firmware Cloning

Enhanced Controller Firmware Auto-Cloning allows customer choice of controller firmware version when adding redundant controller with different firmware version. Easy to manage functionality through controller LCD panel at time of installation.

Multi Host Storage Sharing

Selective Storage Presentation (SSP) support standard on both the base 2-port model of Modular Smart Array 500 G2 as well as the optional MSA 500 G2 4-port I/O Module. SSP allows the administrator to create volumes and assign access rights to a particular host server. This allows sharing the Modular Smart Array 500 G2 with up to 4 host servers maximizing storage capacity utilization. SSP also allows online capacity expansion as well as online volume extension in DAS configurations.

Modular Smart Array 500 G2 Components

- RAID** Several fault tolerant configurations keep data available and servers running while drives are being replaced, including:
- Advanced Data Guarding (RAID ADG): Allocates the equivalence of 2 parity drives across multiple drives and allows simultaneous write operations.
 - Distributed Data Guarding (RAID 5): Allocates parity data across multiple drives and allows simultaneous write operations.
 - Drive Mirroring (RAID 1 and 1+0 Striped Mirroring): Allocates half of the drive array to data and the other half to mirrored data, providing two copies of every file.

Modular Smart Array 500 Controller Cache G2 Cache Upgrade and Fault Recovery

- Cache on the Modular Smart Array 500 G2 Controller may be upgraded to a maximum of 512 MB.

NOTE: The Modular Smart Array 500 G2 Controller allows the following cache configurations: 1 x 256 MB; 2 x 256 MB

NOTE: When redundant controllers are installed, the cache configurations in both controllers must be identical.

Fault Recovery

- Rapid Drive Rebuild -- minimizes downtime, reconstructs data, and facilitates a quick recovery from drive failure.
- On-Line Spares: If a failure occurs, recovery begins with an on-line spare and data is reconstructed automatically. One on-line spare can be assigned per array and used across multiple arrays. It is also possible to assign different on-line spares across different arrays.
- Array Accelerator: Onboard, battery-backed cache memory protects data in the event of a power failure. In the unlikely event of a controller failure, the battery-backed cache will save critical user data for up to three days.

Ultra320 SCSI I/O Module

- The I/O module on the Modular Smart Array 500 G2 includes an integrated Environmental Monitoring Unit which performs several functions including monitoring the enclosure functions, providing I/O connectors and signaling enclosure status. Modular Smart Array 500 G2 ships standard with a 2-Port I/O Module. The MSA500 G2 4-Port I/O Module with Smart Array Multipath is available as an option.
- The 4-Port Shared Storage Module may be deployed as follows: 4-node cluster with Linux (LifeKeeper and Serviceguard) and NetWare, Multiple I/O paths to a two attached servers (2-node cluster or shared storage), and as the shared storage component with up to four servers in a configuration.

NOTE: For additional information regarding ProLiant Server compatibility, please refer to the following URL:

<http://www.hp.com/go/msa> for latest compatibility

Software Components

The Modular Smart Array 500 G2 utilizes a single, consistent set of utility software for storage and RAID management, setup, configuration and troubleshooting. This consistency reduces the cost of ownership by reducing the training and technical expertise necessary to install and maintain your HP server storage solution.

Configuration Utilities Array Configuration Utility (ACU) [On-line for Microsoft and Linux, Remote Web-Based & Off-line, CPQONLIN for NetWare On-line configuration]
Option ROM Configuration for Arrays (ORCA)

**Management/
Health Utilities** System Insight Manager

Array Configuration Utility (ACU)

- Provides a graphical view of HP drive array configurations.
- Easy to use Wizards for configuration.
- Web Based ACU supports On-Line, Remote Web Based and Off-line configuration.
- Supports on-line configuration for Microsoft and Linux.
- Configures Selective Storage Presentation (SSP).

System Insight Manager

- Powerful storage, server and server option management tool.
- Monitor storage from a remote central location.
- Browser based Insight Manager 7 provides full access from anywhere on the Intranet, eliminating the need for a dedicated Insight Manager console.

Supported Operating Systems

- Microsoft Windows Server 2003 Web Edition
- Microsoft Windows Server 2003 Standard Edition
- Microsoft Windows Server 2003 Enterprise Edition
- Microsoft Windows 2000 Server
- Microsoft Windows 2000 Advanced Server
- Novell NetWare 5.1
- Novell NetWare 6.5, 6.5 SBS
- Red Hat Enterprise Linux AS, ES, 2.1, 3
- Red Hat Enterprise Linux 3.0
- SuSE Linux Enterprise Server 9 (SLES9)
- UnitedLinux 1.0AS, ES,

UnitedLinux 1.0 (including SuSE Linux Enterprise Server 8)

UnitedLinux = Conectiva Linux Enterprise Edition, SCO Linux 4.0, SuSE Linux Enterprise 8 and TurboLinux 8 all powered by UnitedLinux 1.0

Not all configurations are supported on all operating systems; please refer to compatibility matrix

<http://www.hp.com/products/sharedstorage> for latest compatibility information.

Software Components

Supported Clustering Solutions

- Microsoft Cluster Service for Microsoft Windows Server 2003 Enterprise Edition
- Microsoft Cluster Service for Microsoft Windows 2000 Advanced Server
- Novell Cluster Services on Novell NetWare 5.1
- Novell Cluster Services on Novell NetWare 6.5
- HP Serviceguard for Linux on Red Hat Enterprise Linux 2.1, Red Hat Enterprise Linux 3.0, UnitedLinux 1.0, SuSE Linux Enterprise Server 8, 9
- SteelEye's LifeKeeper for Linux on Red Hat Enterprise Linux AS, ES 2.1, Red Hat Enterprise Linux AS, ES3, UnitedLinux 1.0, and SuSE Linux Enterprise Server, 9.

UnitedLinux = Conectiva Linux Enterprise Edition, SCO Linux 4.0, SuSE Linux Enterprise 8 and TurboLinux 8 all powered by UnitedLinux 1.0

Please refer to the HP High Availability Web site:

<http://h18000.www1.hp.com/solutions/enterprise/highavailability/> for latest information

Services and Support, HP Care Packs and Warranty Information

Service and Support

Hardware diagnostic support and repair is available for three years from date of purchase. Support for software and initial setup is available for 90 days from date of purchase. Additional support may be covered under the warranty or available for an additional fee. Enhancements to warranty services are available through HP Care Pack services or customized service agreements.

NOTE: Limited warranty includes 3 year parts, 3 years labor, 3 years on-site support

Care Pack services provide a range of life cycle support options that let you choose the service levels that meet your business requirements, from basic to mission-critical.

A full range of HP Care Pack hardware and software services are available including:

- Installation and start up
- Education courses
- Extended onsite hardware coverage hours from same business day 13 hours, 5 day to 24 hours, 7 days call window with options including 4-hour response or 6-hour Call To Repair
- Comprehensive range of software technical support for Microsoft, Linux, ProLiant Essentials and VMware-based IT solutions helping to deliver high level of application availability. Response times range from 30 mins for critical problems to 2 hours.
- System Management, Performance Services and Mission Critical Support Solution

Service includes HP branded hardware options qualified for the storage enclosure, purchased at the same time or afterwards, internal to the enclosure. These will be covered at the same service level and coverage period as the storage enclosure.

NOTE: For more information on HP Care Pack services, contact any of our worldwide sales offices or resellers or visit our worldwide Web site on the internet at: <http://www.hp.com/hps/carepack>.

NOTE: For more complete information on HP Services offerings, customers and resellers, please visit us at: <http://www.hp.com/hps>.

NOTE: Additional information regarding worldwide limited warranty and technical support is available at: <http://h18004.www1.hp.com/products/servers/platforms/warranty/index.html>.

NOTE: For additional information on Server Services, Rack and Power Options, please visit: <http://h20219.www2.hp.com/services/cache/111072-0-0-225-121.html>

NOTE: The information contained herein is subject to change without notice and is provided "as is" without warranty of any kind.

NOTE: The warranties for HP products and services are set forth in the express limited warranty statements accompanying such products and services.

NOTE: Nothing herein should be construed as constituting an additional warranty. HP shall not be liable for technical or editorial errors or omissions contained herein.

Services and Support, HP Care Packs and Warranty Information

HP Care Pack	3 Yr 4h 13x5	U6455E
Fixed Price Care Pack	3 Yr 4h 24x7	U6456E
	3 Yr 6h CTR	U6457E
	1 Yr 4h 13x5	U8148E
	1 Yr 4h 7x24	U8149E
	1 Yr 6h CTR	U8150E
	Hardware Installation	U6458E

HP Care Pack	Support - MSA500, 1 Yr ND Hardware	HA101A1-7GN
Flexible Care Pack	Support - MSA500, 3 Yr ND Hardware	HA101A3-7GN
	Support - MSA500, 1 Yr 4h 13x5 Hardware	HA103A1-7GN
	Support - MSA500, 3 Yr 4h 13x5 Hardware	HA103A3-7GN
	Support - MSA500, 1 Yr 4h 2x7 Hardware	HA104A1-7GN
	Support - MSA500, 3 Yr 4h 24x7 Hardware	HA104A3-7GN
	Support - MSA500, 1 Yr 6h CTR Hardware	HA105A1-7GN
	Support - MSA500, 3 Yr 6h CTR Hardware	HA105A3-7GN
	Support - MSA500, 1 Yr Support Plus	HA109A1-7GN
	Support - MSA500, 3 Yr Support Plus	HA109A3-7GN
	Support - MSA500, 1 Yr Support Plus 24	HA110A1-7GN
	Support - MSA500, 3 Yr Support Plus 24	HA110A3-7GN
	Support - MSA500, Installation	HA113A1-564

Configuration Information

Step 1: Order Required Items

Models	HP Modular Smart Array 500 G2 (includes 2 HBA Adapters)	335880-B21
---------------	---	------------

Package Contents	Modular Smart Array 500 G2 Chassis Modular Smart Array 500 G2 Controller with 256MB cache 2-port Ultra320 SCSI I/O Module Redundant Hot Pluggable Power Supply/blower assemblies 2 HBA - Smart Array 642 Adapters Modular Smart Array 500 G2 Rack Mounting Kit Modular Smart Array 500 G2 Support Software or Smart Start Power cables (2) VHDCI SCSI cables 6' each (2) Crossover Ethernet cable for clustering User Manual
-------------------------	--

Step 2: Choose Modular Smart Array 500 G2 System Options

Options	Modular Smart Array 500 G2 High Availability Kit (includes MSA500 G2 controller, MSA500 G2 4-port IO Module, Smart Array Multipath Software and 2 SA-642 Adapters)	360229-B21
	Modular Smart Array 500 G2 Controller	335881-B21
	MSA500G2 4-Port I/O Module with Smart Array Multipath Software	335882-B21
	256MB Battery Backed Cache Module	254786-B21
	M-Series Rack Rail Kit Option	313877-B21

Step 3: Choose ProLiant Server(s)

Server Compatibility	ML350 G3, G4, G5 ML370 G3, G4, G5 ML530 G2 ML570 G2, G3, G4 DL360 G3, G4, G5 DL380 G3, G4, G5 DL385 DL560 DL580 G2, G3, G4 DL585, G2 DL740 DL760 G2
-----------------------------	--

For additional information regarding ProLiant Server compatibility, please refer to the following URL:
<http://www.hp.com/go/msa> for latest compatibility

Configuration Information

Step 4: Choose Linux Clustering Configuration Options

High Availability Software	HP Serviceguard for Linux ProLiant Cluster A.11.16 for SUSE SLES 9 & 10 and Red Hat EL 3 & 4 (2 node license cluster kit)	305199-B26
	HP Serviceguard for Linux A.11.16 for SUSE SLES 9 & 10 and Red Hat EL 3 & 4 (single license version)	307754-B26
	SteelEye LifeKeeper for Linux	
	See http://h18004.www1.hp.com/solutions/enterprise/highavailability/linux/index.html	
	NOTE: Above options not required for Microsoft clustering, Novell clustering or non-clustered shared storage configurations	

Step 5: Choose Hard Drives

Pluggable, Universal Hard Drives	U320 SCSI - Hot Plug	
	HP 72GB U320 10K Universal HDD	286714-B22
	HP 146GB U320 10K Universal HDD	286716-B22
	HP 300GB U320 10K Universal HDD	350964-B22
	HP 36GB U320 15K Universal HDD	286776-B22
	HP 72GB U320 15K Universal HDD	286778-B22
	HP 146GB U320 15K Universal HDD	347708-B21
	HP 300GB U320 15K Universal HDD	411089-B22
	NOTE: All U320 Universal Hard Drives are backward compatible to U2 or U3 speeds.	
	NOTE: For complete compatibility information, refer to the HP SCSI Hard Drive Compatibility table located at http://www.compaq.com/products//hdd/hotplug.html	

Step 6: Choose Rack Option

HP Rack 5000 Series (Metallic Carbonite)	HP 5642 RACK-UNASSEMBLED	358254-B21
	NOTE: Please see the HP Rack 5642 QuickSpecs for additional part numbers and Technical Specifications such as height, width, depth, weight, and color: http://h18000.www1.hp.com/products/quickspecs/12074_div/12074_div.HTML (Worldwide)	
	NOTE: For additional information regarding Rack Cabinets, please see the following URL: www.hp.com/go/rackandpower .	
Rack Options for Rack 5000 Series	Stabilizer Kit for 5642 rack (Graphite Carbon)	374493-B21
	NOTE: The stabilizer kit is used to prevent rack from tipping over	
	Baying Kit for 5642 rack (Graphite Carbon)	374499-B21
	NOTE: The baying kit is used to join two or more HP 5642 racks.	

HP Rack 10000 Series	Rack, HP Infrastructure 42U (LV)	379006-001
-----------------------------	----------------------------------	------------

Configuration Information

(Graphite Metallic)	Rack, HP Infrastructure 42U (HV)	379005-001
	HP S10614 (14U) Rack Cabinet - Shock Pallet	292302-B22
	HP 10842 (42U, 800mm wide) Rack Cabinet - Pallet	257415-B21
	HP 10842 (42U, 800mm wide) Rack Cabinet - Shock Pallet	257415-B22
	NOTE: Server Blade Enclosures must be field integrated into the 10842 racks. Factory integration of Server Blade Enclosures into the 10842 is not supported	
	HP 10647 (47U) Rack Cabinet - Pallet	245160-B21
	HP 10647 (47U) Rack Cabinet - Shock Pallet	245160-B23
	HP 10636 (36U) Rack Cabinet - Crated	245163-B21
	HP 10622 (22U) Rack Cabinet - Shock Pallet	245163-B22
	HP 10622 (22U) Rack Cabinet - Crated	245163-B23
	NOTE: xxxxx-B21 (pallet) used to ship empty racks shipped on a truck. xxxxx-B22 (shock pallet) used to ship racks with equipment installed (by custom systems, VARs and Channels). xxxxx-B23 (crated) used for air shipments of empty racks.	
	NOTE: It is mandatory to use a shock pallet in order to ship racks with equipment installed	
	NOTE: Please see the Rack 10000 QuickSpecs for additional part number and Technical Specifications such as height, width, depth, weight, and color: http://h18000.www1.hp.com/products/quickspecs/10995_div/10995_div.HTML (Worldwide)	
	NOTE: For additional information regarding Rack Cabinets, please see the following URL: www.hp.com/go/rackandpower .	

DtS Expansion Options

SAN Conversion Options	HP StorageWorks MSA1000 High Availability Upgrade Kit for Windows	353804-B21
	NOTE: Includes (1) redundant controller; (1) MSA SAN Switch 2/8; (2) FCA2214 HBAs; cables plus a ProLiant HA/F200 kit with Secure Path for two servers. Designed as an upgrade for the MSA500 G2	
	HP StorageWorks MSA1000 High Availability Upgrade Kit for Linux	353805-B21
	NOTE: Includes (1) redundant controller; (1) MSA SAN Switch 2/8; (2) FCA2214 HBAs; cables plus Secure Path for Linux Workgroup Edition for two servers. Designed as an upgrade for the MSA500 G2	
	Modular Smart Array 1000 Controller	218231-B22
	MSA Fibre Channel I/O Module	218960-B21
	MSA SAN Switch 2/8 (Integrated)	288247-B21
	FCA2101 Host Adapter (Microsoft)	245299-B21
	2Gb/s SFP SW Transceiver Kit	221470-B21
	Modular Smart Array 30 Single Bus (rack-mountable)	302969-B21
	NOTE: The MSA 1000 controller and the MSA 1000 Fibre Channel I/O module (or the MSA SAN Switch 2/8) are required for conversion. To obtain conversion procedure document go to http://www.hp.com/go/msa500 and download "Converting Modular Smart Array 500 to a Modular Smart Array 1000 for Additional Scalability document.	

Technical Specifications

Modular Smart Array 500 G2

LED Indicators on Front (3)	Power	
	Fault detected in one or more sub-systems	
	Fault in Enclosure Management	
LED Indicators for Drive Modules (3)	Drive Access (center)	
	Online (left)	
	Drive Failure (right)	
LED Indicators on Rear Panel (4)	Power Supply/Blower Assembly Fault (1)	
	EMU (3): Power; A bus; B bus	
Interface	Ultra320 SCSI to Hard Drives	
	Ultra320 SCSI to Host Servers	
Maximum Number of Drives	14, 1-in Ultra320, Ultra3 or Ultra2 Universal Hard Drives (Modular Smart Array 500 G2 cabinet)	
Temperature Range	Operating	50° to 95° F (10° to 35° C)
	Shipping	-2° to 122° F (-0° to 50° C) NOTE: Rated 1°C per 1000 feet of elevation to 10000 ft.
Relative Humidity	Operating	10% to 90%
	Non-operating	Up to 95%
Input Power Requirements	Rated Input Voltage	100 to 240 VAC
	Rated Input Frequency	50 to 60 Hz
	Rated Input Current	2.3 A at 120 VAC typical, 6A Maximum
	Input Power (max)	549 W*
Heat Dissipation (maximum)	1876 Btu/hr*	
*Input Power and Heat Dissipation specifications are maximum values and apply to worst-case conditions at full rated power supply load. The power/heat dissipation for your installation will vary depending on the equipment configuration.		
2-Port SCSI I/O Module	Ports	2 VHDCI Ultra320 SCSI ports
	Dimensions	4.5 x 1.375 x 9.5 in (11.4 x 3.5 x 24.1 cm)
	Weight	1.3 lb (0.6 Kg)
Smart Array 642 Adapters	Protocol	Ultra320 SCSI
	SCSI Electrical Interface	Low Voltage Differential (LVD)
	SCSI Port Connectors	One external and one internal SCSI port
	Channel Transfer Rate	640-MB/s total; 320-MB/s per channel
	PCI Bus Speed	64-bit, 133-MHz PCI-X (1 GB/s maximum bandwidth)
	PCI	3.3 volt CPI slot compatibility only
	Dimensions (H x W x D)	12.3 x 4.2 x 0.6 in (31.24 x 10.7 x 1.5 cm)
Modular Smart Array 500 G2 Cabinet	4U Rack Form Factor	
	Dimensions (H x W x D)	6.9 x 19 x 20.5 in (17.5 x 48.3 x 52.1 cm)
	Weight (Net)	50 lb (22.5 kg)
Shipping Packaging	Dimensions (L x W x D)	33.7 x 14.8 x 33.8 in (85.6 x 37.5 x 85.9 cm)

Technical Specifications

Weight (Gross) 70 to 105 lb (31.5 kg)

Modular Smart Array 500 G2 Controller

User Interface	Controller Display with Status Indicators (2) and Push Buttons (4) Status Indicators on front of Controller (16)
Electrical Interface	LVD (Low Voltage Differential)
Protocol Support	Wide Ultra320 SCSI (320 MB/s per channel)
SCSI Channels	4 total. 2 Ultra320 SCSI channels supporting up to 4 host servers. 2 Ultra320 SCSI channels supporting 14 disk drives (7 drives per channel). 640 MB/s maximum transfer rate
Drives Supported	Up to 14 drives
Maximum Capacity	4.2 TB (14 drives x 300GB)
Logical Drives	Up to 32 logical drives
RAID Support	RAID ADG (Advanced Data Guarding) RAID 5 (Distributed Data Guarding) RAID 1+0 (Striping & Mirroring) RAID 1 (Mirroring) RAID 0 (Striping)
Cache Memory	Standard 256 MB Read/Write Cache Up to 512 MB Read/Write with second 256MB cache module ECC protection, battery-backed, and removable NOTE: The Modular Smart Array Controller allows the following cache configurations: 1 x 256 MB; 2 x 256 MB. NOTE: When redundant controllers are installed, the cache configurations in both controllers must be identical.
Cache Batteries	Up to three days of redundant battery life, removable for easy replacement
Upgradeable Firmware	2 MB flashable ROM
Disk Drive and Enclosure Protocol Support	Ultra320, Ultra3 and Ultra2 SCSI 1-inch Universal drives
Packaging	Dimensions (L x W x D) 14.5 x 11.5 x 3.1 in (36.8 x 29.2 x 8 cm) Weight (Gross) 6 lb (2.72 kg)

MSA500 G2 Shared Storage I/O Module (option)

Connector Type	VHDCI Ultra320 SCSI
Ports	4 Ultra320 SCSI
Bandwidth	320 MB/s per port
Protocols/HBA Supported	Ultra320/Smart Array 642, Smart Array 6i adapters
Software	Smart Array Multipath software 2.0B
Packaging	Dimensions (L x W x D) 14.5 x 11.5 x 3.1 in (36.8 x 29.2 x 8 cm) Weight (Gross) 6 lb (2.72 kg)

Technical Specifications

MSA500 G2 High Availability Kit (option)

Contents	MSA500 G2 Controller, 4-port Shared Storage I/O Module, 2 6ft. SCSI Cables, 2 SA-642 Adapters, and Smart Array Multipath Software 2.0B	
Packaging	Dimensions (L x W x D)	18 x 12 x 10 in. (45.7 x 30.5 x 25.4 cm)
	Weight (Gross)	8 lb (3.6 kg)

© Copyright 2007 Hewlett-Packard Development Company, L.P.
The information contained herein is subject to change without notice.

Microsoft and Windows NT are US registered trademarks of Microsoft Corporation.

The only warranties for HP products and services are set forth in the express warranty statements accompanying such products and services. Nothing herein should be construed as constituting an additional warranty. HP shall not be liable for technical or editorial errors or omissions contained herein.

For hard drives, 1 GB = 1 billion bytes. Actual formatted capacity is less.