

Overview

The next generation in switching technology. The Cisco Catalyst Blade Switch 3120 Series Switches are specifically designed to meet the rigors of the blade server based application infrastructure and provides HP BladeSystem customers with the ability to stack up to nine switches into a single virtual Switch. By emulating a redundant top-of-rack switch, HP BladeSystem c-Class users now have an integrated switching solution from Cisco Systems that optimizes uplinks per rack, reduces the number of switches managed and decreases network complexity. Both switches also provide Cisco resiliency, advanced security and enhanced manageability to the server edge while dramatically reducing cabling requirements. The Cisco Catalyst Blade Switch 3120 comes in two versions. The 3120G is a 1Gb switch with the flexibility to provide both copper and fiber uplinks. The 3120X has sixteen 1Gb downlinks and both 1Gb and 10Gb uplinks that can be used to aggregate bandwidth from multiple enclosures, or be used as a stand-alone switch in high bandwidth applications. The Cisco CBS3120 offers operational consistency with the rest of the industry leading Cisco Catalyst series of switches, using the familiar IOS Command Line Interface (CLI), consistent MIBs, and management tools like CiscoWorks. Furthermore, this consistency with the rest of the Cisco Catalyst series ensures end-to-end network service like QoS are consistently implemented across the network.

Both switches can be upgraded with additional firmware add-ons available at time of purchase or through web downloads.

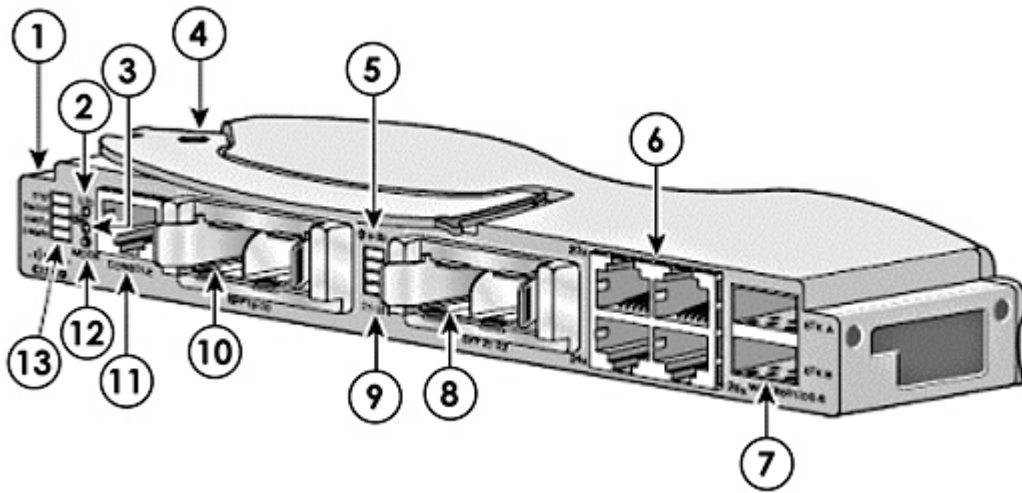

Cisco Catalyst Blade Switch 3120 Series

- | | |
|--|---|
| 1. Switch Module | 8. Slot for Cisco Twin Gigabit Module or X2 Transceiver module. |
| 2. UID LED | 9. LEDs for ports 21 -22 |
| 3. Health LED | 10. Slot for Cisco Twin Gigabit Module or X2 Transceiver module |
| 4. Release latch | 11. Console Port |
| 5. LEDs for ports 19 -20 | 12. Mode Button |
| 6. Gigabit Ethernet RJ-45 Ports 23 -26 | 13. Switch System LED Panel |
| 7. StackWise Ports | |

What's New

- Support for new HP ProLiant G7 server blades



Models and Options

Models	
Cisco Catalyst Blade Switch 3120X for HP	451439-B21
Cisco Catalyst Blade Switch 3120G for HP	451438-B21
Options	
Cisco Ethernet RJ-45 SFP Module	378928-B21
Cisco Ethernet Fiber LC SFP module	378929-B21
NOTE: The modules listed below support Cisco Catalyst Blade Switch 3120X for HP (p/n 451439-B21) only	
Cisco 10GBASE-CX4 X2 Module	459005-B21
Cisco 10GBASE-SR X2 Module	459006-B21
Cisco 10GBASE-LRM X2 Module	459007-B21
NOTE: The software upgrade listed below support the Cisco Catalyst Blade Switch 3120X and 3120G Switches.	
HP Catalyst Blade Switch 3120 IP Service Software Upgrade	455046-B21
NOTE: Full IPv6 routing with EIGRPv6, OSPFv3.	
NOTE: The cable options listed below support the Cisco Catalyst Blade Switch 3120X and 3120G Switches.	
Stacking Cable for Cisco 3120, 3.0 Meter	494330-B21
Stacking Cable for Cisco 3120, 1.0 Meter	494332-B21
Stacking Cable for Cisco 3120, 0.5 Meter	494331-B21



Standard Features

Standard Features

Performance

- Wire speed switching on sixteen internal 1Gb ports
- Wire Speed switching on four external 10/100/1000BASE-T ports. (Two of these ports can be used as cross-connects to provide failover protection)
- Wire speed switching on four external 10/100/1000 SFP based ports that can be configured in addition to the four 10/100/1000BASE-T ports to support Fiber SX/LX SFP modules from Cisco Systems
- Two external 10Gb X2 based ports that support SR, LR, LRM and CX4 modules (Cisco Catalyst Blade Switch 3120X only)
- Two 64Gb stacking ports
- One external console port

Management

- CiscoWorks Software that includes multilayer feature configurations such as routing protocols, ACLs, and QoS parameters
- Compatible with Cisco Network Assistant
- Supports both Embedded Events Manager (EEM) and Generic On-line Diagnostics (GOLD)
- IOS CLI support providing a common user interface and command set with all Cisco routers and Cisco Catalyst desktop switches
- The Catalyst Blade Switch 3120 series supports an embedded Remote Monitoring (RMON) software agent for enhanced traffic management, monitoring and analysis

Security

- VLAN - Virtual Local Area Network is a logical network topology configured on top of a physical network topology which conserves bandwidth and improves security by limiting traffic to specific groups of devices
- Supports Cisco's Identity-Based Networking Services (IBNS) which prevents unauthorized network access and insures that users get only their designated privileges
- Compatible with Cisco Secure Access Control Server (ACS) so that user security profiles and authentication follow the user regardless of where they connect on the network
- Access Control Lists (ACL's) are maintained in hardware for maximum performance and can be used to guard against denial-of-service and other attacks
- 802.1x Port Security recognizes the MAC address of the device connecting to it and will set rights or limitations based on predefined security thresholds

Stacking

- Up to nine 3120 switches can be combined into a single virtual stack.
 - Switches can be managed as a single virtual switch with a single IP address and single routing domain.
 - 64 Gb stacking fabric provides flexible and redundant ring architecture eliminating any single point of failure.
-



Standard Features

Compatibility

HP ProLiant Servers

HP ProLiant BL2x220c G7
HP ProLiant BL2x220c G5
HP ProLiant BL260c G5
HP ProLiant BL280c G6
HP ProLiant BL460c G7
HP ProLiant BL460c G6
HP ProLiant BL460c G5
HP ProLiant BL460c
HP ProLiant BL465c G7
HP ProLiant BL465 G6
HP ProLiant BL465 G5
HP ProLiant BL465c
HP ProLiant BL480c
HP ProLiant BL490c G7
HP ProLiant BL490c G6
HP ProLiant BL495c G6
HP ProLiant BL495c G5
HP ProLiant BL620c G7
HP ProLiant BL680c G5
HP ProLiant BL680c G7
HP ProLiant BL685c G7
HP ProLiant BL685 G6
HP ProLiant BL685 G5
HP ProLiant BL685c

NOTE: Some servers listed above may be discontinued.

HP Integrity Server Blade

HP Integrity BL860c Server Blade
HP Integrity BL860c i2 Server Blade
HP Integrity BL870c Server Blade
HP Integrity BL870c i2 Server Blade
HP Integrity BL890c i2 Server Blade

HP ProLiant c-Class

Server Blade Enclosures

HP BladeSystem c3000 Enclosure
HP BladeSystem c7000 Enclosure



Standard Features

Required Network Cabling	10Base-T	Categories 3, 4 or 5 UTP (100 meters) EIA/TIA-568 100-ohm STP (100 meters)
	100Base-TX	Category 5 UTP (100 meters) EIA/TIA-568 100-ohm STP (100 meters)
	1000Base-T	Category 5 UTP (100 meters) EIA/TIA-568 100-ohm STP (100 meters)
	1000Base-SX	50/125 μm Multimode Fiber, 400 MHz/Km (500 meters) 50/125 μm Multimode Fiber, 500 MHz/Km (550 meters) 62.5/125 μm Multimode Fiber, 160 MHz/Km (220 meters) 62.5/125 μm Multimode Fiber, 200 MHz/Km (275 meters)
	1000Base LX	Operates on standard single-mode fiber-optic link spans of up to 10 km and up to 550 m on any multimode fibers.
	10Gb	Multimode fiber cable; 62.5/125 or 50/125 microns Singlemode fiber cable: 9/125 micron The following CX4 cable lengths have been qualified and can be purchased directly from HP. HP BLadeSystem c-Class .5m 10-GbE CX4 Cable HP BLadeSystem c-Class 1m 10-GbE CX4 Cable HP BLadeSystem c-Class 15m 10-GbE CX4 Cable



Service and Support

Service and Support

HP Care Pack Services: Packaged server and storage services for increased uptime, productivity and ROI

When you buy HP server and storage products and solutions, it's also a good time to think about what levels of support you may need. Our portfolio of service options reduce deployment and management worries while helping you get the most out of your server and storage investments. We take a holistic approach to your environment, bridging servers, blades, storage, software and network infrastructures with our packaged HP Care Pack Services for servers and storage.

Protect your business beyond warranty

When it comes to robustness and reliability, standard computing equipment warranties have matured along with technology. Good news that can also create problems stemming from depending on standard warranties designed to only protect against product defects and some downtime causes. Using a standard approach to warranty uplifts, such as HP Care Pack Services, helps reduce downtime risks and provides operational consistency for mission-critical and standard business computing.

HP Care Pack Services: Upgrading or extending standard server and storage warranties cost effectively

HP Care Pack Services offer a standard reactive hardware and software support services suite sold separately, or combined with our Support Plus and Support Plus 24 services. The portfolio also provides a combination of integrated proactive and reactive services, such as Proactive 24 Service and Critical Service. In addition with HP Proactive Select, you can acquire the specific proactive constancy and technical services. HP Proactive Select menu offers a broad set of service options that you can mix and match depending on your specific requirements. Proactive service options include offers for server, storage, network, SAN device, software, environment and education services.

HP server and storage lifecycle support services offers a full spectrum of customer care-from technology support to complex migrations to complete managed services. HP Factory Express provides customization, integration and deployment services for turnkey solutions. HP Education Services offer flexible, comprehensive training on to help your IT staff get the most out of your server and storage investments. HP Financial solutions extend innovative financing and cost-effective asset management programs-from purchase to equipment retirement.

Learn more: www.hp.com/services/servers and www.hp.com/services/storage

NOTE: Care Pack Services availability may vary by product and country.

HP Care Pack Services are sold by HP and HP Authorized Service Partners:

- Services for customers purchasing from HP or an enterprise reseller are quoted using HP order configuration tools.
- Customers purchasing from a commercial reseller can find HP Care Pack Services at <http://www.hp.com/go/lookuptool>



Service and Support

Recommended HP Care Pack Services for optimal satisfaction with your HP product

Recommended Services **Hardware Options Support**

HP Care Packs provide support for all HP-branded hardware options qualified for inclusion in your server or storage solution. Any additional HP-qualified options installed within the server are covered at the same service level and for the same period as the server and no additional cost.

- Help improve or maintain system uptime
- Convenient onsite support
- Committed response time

<http://h20195.www2.hp.com/V2/GetPDF.aspx/5982-6547EEE>

3-Year HP Hardware Support Onsite Service, 4-hour response, 24x7

Provides you with rapid remote support and if required an HP authorized representative who will arrive on site any time and day of the year to begin hardware maintenance service within 4 hours of the service request being logged.

This service provides a trained HP service specialist to perform an installation that meets HP quality standards, for:

- Help improve or maintain system uptime
- Convenient onsite support
- Committed response time

<http://h20195.www2.hp.com/V2/GetPDF.aspx/5982-6547EEE>

HP Installation and Startup of HP ProLiant Servers

Provides for the installation of your new HP ProLiant server and operating system to assist you in bringing your new HP ProLiant server and operating system into operation in a timely and professional manner.

This service provides a trained HP service specialist to perform an installation that meets HP quality standards, for:

- Delivery of the service at a mutually scheduled time convenient to your organization
- Availability of an HP service specialist to answer basic questions during the onsite delivery of this service
- Custom installation as detailed in "Delivery specifications" or in a Statement of Work (SOW)
- Verification prior to installation that all service prerequisites are met

<http://h20195.www2.hp.com/V2/GetPDF.aspx/5982-7572ENN.pdf>



Service and Support

Optional HP Care Pack Services that will enhance your HP product experience

Optional Services

3-Year HP Hardware Support Onsite Call-to-Repair (CTR) Service, 6- or 24-hour

As an alternative to our recommended support level, for customers who need committed call-to-repair for server hardware.

Provides your IT manager with a team of support specialists who will quickly begin troubleshooting the system to help return the hardware to operating condition within 6 or 24 hours of the initial service request to the HP Global Solution Center.

<http://h20195.www2.hp.com/V2/GetPDF.aspx/5982-6547EN.pdf>

3-Year HP Support Plus 24

As an alternative to our recommended support level, for customers who need access to responsive 24x7 hardware and software support plus software updates on HP and selected third party products:

For a higher return on your server and storage technology, our 3-year combined reactive support service delivers integrated onsite hardware/software support services available 24x7x365, including access to HP technical resources, 4-hour response onsite hardware support and software updates.

<http://h20195.www2.hp.com/V2/GetPDF.aspx/5981-6638EEE>

HP Proactive Select Service

Customer needs on demand access to consulting, technical proactive services and education courses

Provides a flexible way to purchase HP best-in-class consultancy and technical services. You can buy Proactive Select Service Credits when you purchase your hardware and then use the credits over the next 12 months.

<http://h20195.www2.hp.com/V2/GetPDF.aspx/4AA2-3842ENN>

eSupport

HP eSupport is a portfolio of technology-based services that assist you with managing your business environment - from the desktop to the data center.

Support Portal

The HP support portal provides one-stop access to the information, tools and services you need to manage the daily operations of your IT environment.

Features include:

- Access to self-solve tools (including search technical knowledge base)
- Efficient logging and tracking of support cases
- Collaboration with other business and IT professionals
- Download of patches and drivers
- Access to diagnostic tools
- Proactive notification of relevant information

Access to certain features of the support portal requires an HP service agreement. To access the support portal, visit: <http://www.hp.com/support>



Service and Support

HP Insight Remote Support software delivers secure remote support for your HP Servers and Storage, 24 X 7, so you can spend less time solving problems and more time focused on your business. You can have your systems remotely monitored for hardware failure using secure technology that's been proven at thousands of companies around the world. In many cases, you can avoid problems before they occur.

Customer Technical Training

In today's cost-conscious business environment, IT professionals, developers, consultants and users face an interesting challenge: how to keep up with the latest technologies and expand important skills while delivering profitable results on current projects. To help address this challenge, HP offers innovative training solutions that help keep you up-to-date on virtualization, server, storage, Insight Control, Citrix, Microsoft® and open source/Linux-related topics-while spending less time away from business-critical activities.

HP Services Awards

HP Technology Services continues to be recognized for service and support excellence by customers, partners, industry organizations and publications around the world. Recent honors and award reflect our services team's dedications, technical expertise, professionalism and uncompromising commitment to customer satisfaction.

Additional Services Information

To learn more on HP ProLiant servers, HP BladeSystem servers and HP storage products, please contact your HP sales representative or HP Authorized Channel Partner. Or visit: www.hp.com/services/proliant or www.hp.com/services/bladesystem or <http://www.hp.com/hps/storage>



Related Options

Service and Support Offerings (HP Care Pack Services)

NOTE: HP Care Pack services for the c7000 Enclosure cover the enclosure, power supplies and fans. HP qualified rack options are covered by these services when installed within the same rack. HP supported c-Class enclosure devices including pass thru, Ethernet interconnect and virtual connect modules are also covered by the c7000 enclosure Care Pack services.

NOTE: SAN/Fabric switches for the HP c-Class BladeSystem are not covered under the c7000 enclosure Care Packs, SAN/Fabric switches carry separate Care Packs. SAN/Fabric Switch Care Pack service level support should always be uplifted to match existing storage or server service level.

Hardware Support Services On-site Service

c7000 HP Care Pack Services

Next Business Day On-site Service, 5-Day x 9-Hour Coverage, 3 Years, Electronic UE477E

NOTE: Uplifts the Ethernet devices to the same level of warranty as the c-class enclosure

4-Hour On-site Service, 5-Day x 13-Hour Coverage, 3 Years, Electronic UE478E

4-Hour On-site Service, 7-Day x 24-Hour Coverage, 3 Years, Electronic UE479E

6-Hour Call to Repair, On-site Service, 7-Day x 24-Hour Coverage, 3 Years, Electronic UE480E

Support Plus 24

HP 3 year Support Plus 24 Insight Control Linux Edition BladeSystem c7000 Service UH321E

Onsite HW support 24x7, 4hr response and Insight Control Environment for BladeSystem SW Updates, SW Tech support offsite, onsite at HP's discretion, 24x7 2hr response time including HP holidays, Electronic UH322E

Onsite HW support 24x7, 4hr response and Insight Control Data Center Edition SW Updates, SW Tech support offsite, onsite at HP's discretion, 24x7 2hr response time including HP holidays, Electronic UH323E

Hardware Services On-site Service

c3000 HP Care Pack Services

Next Business Day On-site Service, 5-Day x 9-Hour Coverage, 3 Years, Electronic - uplifts the Ethernet devices to the same level of service as the c-class enclosure UH309E

4-Hour On-site Service, 5-Day x 13-Hour Coverage, 3 Years, Electronic UH310E

4-Hour On-site Service, 7-Day x 24-Hour Coverage, 3 Years, Electronic UH311E

6-Hour Call to Repair, On-site Service, 7-Day x 24-Hour Coverage, 3 Years, Electronic UH312E

Support Plus 24

Onsite HW support 24x7, 4hr response and Insight Control Environment for BladeSystem SW Updates SW Tech support offsite, onsite at HP's discretion, 24x7 2hr response time incl. HP holidays, Electronic UF540E

Installation & Start-up Services

HP BladeSystem c7000 Infrastructure Installation and Startup Service for Blade Hardware and Insight Control Software, Electronic UE602E

HP BladeSystem c3000 + ICE + OS Installation and Startup Service for Blade Hardware and Insight Control Software, Electronic UF817E

HP BladeSystem c3000 Installation & Startup for Blade Hardware and Operating System UF818E



Related Options

HP BladeSystem c7000 Enhanced Network Installation and Startup Service, Electronic	UE603E
HP BladeSystem c3000 Enhanced Network Installation and Startup Service, Electronic	UF814E
ProLiant BL c-Class Blade Server Hardware Installation, Electronic	UE493E
ProLiant BL c-Class Enclosure and Server Blade Hardware Installation, Electronic	UE494E

NOTE: For more information, customer/resellers can contact
<http://www.hp.com/services/bladessystemservices>



Technical Specifications

Shipping Dimensions	Length	13.88 in (352.55mm)
	Width	10.63 in (270.00mm)
	Height	4.75 in (120.65mm)
Shipping Weight		2.0kg (4.4lbs)
Product Specifications Hardware	Performance	128 Gbps switching fabric (Catalyst 3120X)
		64 Gbps stacking fabric
		Forwarding rate based on 64-byte packets; up to 59.2 Mpps
		256 MB DDR SDRAM and 64 MB Flash memory
		Configurable maximum transmission unit (MTU) of up to 9018 bytes (jumbo frames)
		MAC, routing, security, and QoS scalability numbers depend on the type of template used in the switch:

	Default Template	Access Template	VLAN Template	Routing Template
MAC address	6K	4K	12K	3K
IGMP groups and multicast routes	1K	1K	1K	1K
Total unicast routes	8K	6K	0K	11K
Directly connected hosts	6K	4K	0K	3K
Indirect routes	2K	2K	0K	8K
Security ACEs	1K	2K	1K	1K
QoS ACEs	0.5K	0.5K	0.5K	0.5K
PBR ACEs	0	0.5K	0	0.5K

Connectors and Cabling 3120G Gigabit Ethernet uplink ports (Up to 8 external)

- 4 external 10/100/1000BASE-T RJ-45 ports. Two of these ports can be configured to provide an internal crossover connection to an associated additional Cisco Catalyst Blade Switch 3120
- The two supplied Twin-Gig Converter Modules will provide 4 additional external 10/100/1000 SFP combo ports. that support Gigabit Ethernet Fiber SX or LX SFP modules from Cisco Systems.

3120X 1Gb/10Gb Ethernet uplink ports (up to eight external)

- 4 external 10/100/1000BASE-T RJ-45 ports. Two of these ports can be configured to provide an internal crossover connection to an associated additional Cisco Catalyst Blade Switch 3120 when not in stacking mode.
- 2 external 10Gb X2 ports. These ports support CX4, LRM, LX or SX modules. These external ports also support the new Cisco OneX 10G X2 to SFP+ converter.
- The 2 X2 ports can optionally be used to provide up to 4



Technical Specifications

10/100/1000 SFP combo ports using the two supplied Twin-Gig Converter Modules

Management console port:

- RJ-45-to-DB9 cable for PC connections

Stacking Connector

- 1 meter Cisco proprietary StackWise connector cable supplied.
- Additional 1 meter, 0.5 meter and 3 meter Cisco proprietary StackWise connector cable available through HP.

Indicators

Total of 18 LEDs on the face plate

- 12 LEDs for uplink port status
- 4 Switch status LEDs
- 2 HP specific LEDs to indicate Health and UID status

System Unit

Dimensions (L x W x D)

10.5in x 7.5 in x 1.1 in
267.7mm x 92.79mm x 27.94mm

Weight

1.27kg (2.8 lbs)

Environmental Ranges

Temperature Range

Operating Temperature 0 to 43 C (32 to 109 F)

Storage Temperature -20 to 70 C (-4 to 158F)

Operating Relative Humidity 10 to 85%

Humidity

(non-condensing)

Storage Relative Humidity 5 to 95%

(non-condensing)

Power Specifications

12V @ 5A (60 W)

NOTE: Effective April 19th, 2009 Cisco has discontinued the Advanced IP Services upgrade. IPv6 support has been rolled into the IP Services software upgrade (P/N 455046-B21) listed in the Models and Options section below. Many of the IP Services features have been moved to the base IOS effective with IOS 12.2(50)SE. Please see the below chart for details.

Feature	IPv6 Feature Packaging before EOL	Location of IPv6 Features after EOL
EIGRPv6, OSPFv3	Advanced IP Services	IP Services
ACL	Advanced IP Services	IP Base
HSRPv6	Advanced IP Services	IP Base
DHCP, Server/Client/Relay	Advanced IP Services	IP Base
RIPng	Advanced IP Services	IP Base
Static Routes	Advanced IP Services	IP Base

Product Specifications Software

Security Features

The Catalyst Blade Switch 3120 supports a comprehensive set of security features for connectivity and access control, including ACLs, authentication, port-level security, and identity-based network services with 802.1x and extensions. This set of comprehensive features not only helps prevent external



Technical Specifications

attacks, but defends the network against “man-in-the-middle” attacks, a primary concern in today’s business environment. The switch also supports the Network Admission Control (NAC) security framework.

Security features include:

Dynamic ARP Inspection (DAI) helps ensure user integrity by preventing malicious users from exploiting the insecure nature of the ARP protocol.

DHCP Snooping prevents malicious users from spoofing a DHCP server and sending out bogus addresses. This feature is used by other primary security features to prevent a number of other attacks such as ARP poisoning.

IP source guard prevents a malicious user from spoofing or taking over another user’s

IP address by creating a binding table between the client’s IP and MAC address, port, and VLAN.

Unicast RPF feature helps mitigate problems caused by the introduction of malformed or forged (spoofed) IP source addresses into a network by discarding IP packets that lack a verifiable IP source address.

IEEE 802.1x allows dynamic, port-based security, providing user authentication.

IEEE 802.1x with VLAN assignment allows a dynamic VLAN assignment for a specific user regardless of where the user is connected.

IEEE 802.1x and port security are provided to authenticate the port and manage network access for all MAC addresses, including that of the client.

IEEE 802.1x with an ACL assignment allows for specific identity-based security policies regardless of where the user is connected.

IEEE 802.1x with guest VLAN allows guests without 802.1x clients to have limited network access on the guest VLAN.

Web authentication for non-802.1x clients allows non-802.1x clients to use an SSL-based browser for authentication.

Cisco security VLAN ACLs on all VLANs prevents unauthorized data flows from being bridged within VLANs.

Cisco standard and extended IP security router ACLs define security policies on routed interfaces for control-plane and data-plane traffic. IPv6 ACLs can be applied to filter IPv6 traffic.

Port-based ACLs for Layer 2 interfaces allow security policies to be applied on individual switch ports.



Technical Specifications

Secure Shell (SSH) Protocol, Kerberos, and Simple Network Management Protocol Version 3 (SNMPv3) provide network security by encrypting administrator traffic during Telnet and SNMP sessions. SSH Protocol, Kerberos, and the cryptographic version of SNMPv3 require a special cryptographic software image because of U.S. export restrictions.

Bidirectional data support on the Switched Port Analyzer (SPAN) port allows Cisco Intrusion Detection System (IDS) to take action when an intruder is detected.

TACACS+ and RADIUS authentication facilitates centralized control of the switch and restricts unauthorized users from altering the configuration.

MAC Address Notification allows administrators to be notified of users added to or removed from the network.

Port Security secures the access to an access or trunk port based on MAC address.

Multilevel security on console access prevents unauthorized users from altering the switch configuration.

Bridge protocol data unit (BPDU) Guard shuts down Spanning Tree PortFast-enabled interfaces when BPDUs are received to avoid accidental topology loops.

Spanning Tree Root Guard (STRG) prevents edge devices not in the network administrator's control from becoming Spanning Tree Protocol root nodes. IGMP filtering provides multicast authentication by filtering out nonsubscribers and limits the number of concurrent multicast streams available per port.

Spanning Tree Features

IEEE 802.1D Spanning-Tree Protocol support for redundant backbone connections and loop-free networks simplifies network configuration and improves fault tolerance.

Per-VLAN Rapid Spanning-Tree (PVRST+) allows rapid spanning-tree convergence on a per-VLAN spanning-tree basis, without requiring the implementation of spanning-tree instances.

IEEE 802.1s Multiple Spanning-Tree Protocol (MSTP) allows a spanning-tree instance per VLAN and enables each VLAN to use a different uplink allowing better utilization of uplinks.

IEEE 802.1w Rapid Spanning-Tree Protocol (RSTP) provides rapid spanning-tree convergence independent of spanning-tree timers.

Unidirectional Link Detection (UDLD) and Aggressive UDLD allow unidirectional links to be detected and disabled to avoid problems such as spanning-tree loops.

Trunking Features

Cisco UplinkFast and BackboneFast technologies help to ensure quick failover recovery, enhancing overall network stability and reliability.

PVST+ allows for Layer 2 load sharing on redundant links to efficiently use the extra capacity inherent in a redundant design.

Dynamic Trunking Protocol (DTP) enables dynamic trunk configuration



Technical Specifications

VLAN Features

across all switch ports.

Port Aggregation Protocol (PAgP) automates the creation of Cisco Fast EtherChannel® groups or Gigabit EtherChannel® groups to link to the upstream switch/router, or server blades

Link Aggregation Control Protocol (LACP) allows the creation of Ethernet channeling with upstream switches that conform to IEEE 802.3ad. This feature is similar to Cisco EtherChannel technology and PAgP.

Private VLANs restrict traffic between hosts in a common segment by segregating traffic at Layer 2, turning a broadcast segment into a nonbroadcast multi-access-like segment.

Private VLAN Edge provides security and isolation between switch ports, which helps ensure that users cannot snoop on other users' traffic.

Dynamic VLAN assignment is supported through implementation of VLAN Membership Policy Server client capability to provide flexibility in assigning ports to VLANs. Dynamic VLAN facilitates the fast assignment of IP addresses.

Quality of Service Features

Wire-rate performance for highly granular QoS functions (for example, granular rate limiting).

Cross-switch QoS allows QoS to be configured across the entire VBS.

802.1p class of service (CoS) and differentiated services code point (DSCP) field classification is provided, using marking and reclassification on a per-packet basis by source and destination IP address, MAC address, or Layer 4 TCP/UDP port number.

Cisco control-plane and data-plane QoS ACLs on all ports help ensure proper marking on a per-packet basis.

Four egress queues per port help enable differentiated management of up to four traffic types.

Shaped Round Robin (SRR) scheduling helps ensure differential prioritization of packet flows by intelligently servicing the ingress queues and egress queues.

Weighted Tail Drop (WTD) provides congestion avoidance at the ingress and egress queues before a disruption occurs.

Strict priority queuing helps ensure that the highest-priority packets are serviced ahead of all other traffic.

The Cisco committed information rate (CIR) function provides bandwidth in increments as low as 8 Kbps.

Rate limiting is provided based on source and destination IP address, source and destination MAC address, Layer 4 TCP/UDP information, or any combination of these fields, using QoS ACLs (IP ACLs or MAC ACLs), class maps, and policy maps.

Up to 64 aggregate or individual policers are available.

Management Features

Cisco IOS Software CLI support provides common user interface and command set with all Cisco routers and Cisco Catalyst desktop switches.



Technical Specifications

Switching Database Manager Templates for access, routing, and VLAN deployment allow the administrator to easily maximize memory allocation to the desired features based on deployment-specific requirements.

Generic On-Line Diagnostic (GOLD) checks the health of hardware components and verifies proper operation of the system data and control plane at run time and boot time.

Embedded Event Manager (EEM) allows customers to set up trigger points based on certain events to automatically take actions, thus automating network management

VPN routing/forwarding (VRF)-Lite enables a service provider to support two or more VPNs, with overlapping IP addresses.

Local Proxy Address Resolution Protocol (ARP) works in conjunction with Private VLAN Edge to minimize broadcasts and maximize available bandwidth.

VLAN1 minimization allows VLAN1 to be disabled on any individual VLAN trunk.

Smart Multicast, with Cisco Virtual Blade Switch technology, allows the Cisco Catalyst Blade Switch 3120 to offer greater efficiency and support for more multicast data streams such as video by putting each data packet onto the backplane only once.

Internet Group Management Protocol (IGMP) Snooping for IPv4 and IPv6 MLD v1 and v2 Snooping provide fast client joins and leaves of multicast streams and limit bandwidth-intensive video traffic to only the requestors.

Multicast VLAN Registration (MVR) continuously sends multicast streams in a multicast VLAN while isolating the streams from subscriber VLANs for bandwidth and security reasons.

Per-port broadcast, multicast, and unicast storm control prevents faulty end stations from degrading overall systems performance.

Cisco VLAN Trunking Protocol (VTP) supports dynamic VLANs and dynamic trunk configuration across all switches.

Remote Switch Port Analyzer (RSPAN) allows administrators to remotely monitor ports in a Layer 2 switch network from any other switch in the same network.

For enhanced traffic management, monitoring, and analysis, the Embedded Remote Monitoring (RMON) software agent supports four RMON groups (history, statistics, alarms, and events).

Layer 2 traceroute eases troubleshooting by identifying the physical path that a packet takes from source to destination.

Trivial File Transfer Protocol (TFTP) reduces the cost of administering software



Technical Specifications

upgrades by downloading from a centralized location.

Network Timing Protocol (NTP) provides an accurate and consistent timestamp to all intranet switches.

Multifunction LEDs per port for port status;

Jumbo frames (9216 bytes) are available for advanced data and video applications requiring very large frames.

SNMP v1, v2c, and v3 and Telnet interface support deliver comprehensive in-band management, and a CLI-based management console provides detailed out-of-band management.

Cisco Discovery Protocol versions 1 and 2 enable a network-management station for automatic switch discovery.

CiscoWorks Features

CiscoWorks network-management software provides management capabilities on a per-port and per-switch basis, providing a common management interface for Cisco routers, switches, and hubs.

SNMP v1, v2c, and v3 and Telnet interface support deliver comprehensive in-band management, and a CLI-based management console provides detailed out-of-band management.

Cisco Discovery Protocol versions 1 and 2 enable a CiscoWorks network-management station for automatic switch discovery.

Management and Standards Support

Management Information Base (MIB) Support

The MIBs listed in this section are supported in each of IPBase, IPServices, and Advanced IPServices feature sets for both switches.

- BRIDGE-MIB
- CISCO-AAA-SESSION-MIB
- CISCO-ACCESS-ENVMON-MIB
- CISCO-BRIDGE-EXT-MIB
- CISCO-BULK-FILE-MIB
- CISCO-CAR-MIB
- CISCO-CDP-MIB
- CISCO-CIRCUIT-INTERFACE-MIB
- CISCO-CLUSTER-MIB
- CISCO-CONFIG-COPY-MIB
- CISCO-CONFIG-MAN-MIB
- CISCO-DHCP-SNOOPING-MIB
- CISCO-ENTITY-FRU-CONTROL-MIB
- CISCO-ENTITY-VENDORTYPE-OID-MIB
- CISCO-ENVMON-MIB
- CISCO-FLASH-MIB
- CISCO-FTP-CLIENT-MIB
- CISCO-HSRP-EXT-MIB
- CISCO-HSRP-MIB
- CISCO-IF-EXTENSION-MIB
- CISCO-IGMP-FILTER-MIB
- CISCO-IMAGE-MIB
- CISCO-IP-STAT-MIB
- CISCO-IPMROUTE-MIB



Technical Specifications

- CISCO-L2-TUNNEL-CONFIG-MIB
- CISCO-L2L3-INTERFACE-CONFIG-MIB
- CISCO-LAG-MIB
- CISCO-MAC-NOTIFICATION-MIB
- CISCO-MEMORY-POOL-MIB
- CISCO-NTP-MIB
- CISCO-PAE-MIB
- CISCO-PAGP-MIB
- CISCO-PIM-MIB
- CISCO-PING-MIB
- CISCO-PORT-QOS-MIB
- CISCO-PORT-SECURITY-MIB
- CISCO-PORT-STORM-CONTROL-MIB
- CISCO-PRIVATE-VLAN-MIB
- CISCO-PROCESS-MIB
- CISCO-PRODUCTS-MIB
- CISCO-RTTMON-MIB
- CISCO-SMI
- CISCO-STACK-MIB
- CISCO-STACKMAKER-MIB
- CISCO-STACKWISE-MIB
- CISCO-STP-EXTENSIONS-MIB
- CISCO-SYSLOG-MIB
- CISCO-TC
- CISCO-TCP-MIB
- CISCO-UDLD-MIB
- CISCO-VLAN-IFTABLE-RELATIONSHIP-MIB
- CISCO-VLAN-MEMBERSHIP-MIB
- CISCO-VTP-MIB
- DOT3-MAU-MIB
- ENTITY-MIB
- ETHERLIKE-MIB
- HC-RMON-MIB
- IEEE8021-PAE-MIB
- IEEE8023-LAG-MIB
- IF-MIB
- IGMP-MIB
- IPMROUTE-STD-MIB
- OLD-CISCO-CHASSIS-MIB
- OLD-CISCO-CPU-MIB
- OLD-CISCO-FLASH-MIB
- OLD-CISCO-INTERFACES-MIB
- OLD-CISCO-IP-MIB
- OLD-CISCO-MEMORY-MIB
- OLD-CISCO-SYSTEM-MIB
- OLD-CISCO-TCP-MIB
- OLD-CISCO-TS-MIB
- PIM-MIB
- RFC1213-MIB
- RMON-MIB
- RMON2-MIB
- SMON-MIB



Technical Specifications

- SNMP-FRAMEWORK-MIB
- SNMP-NOTIFICATION-MIB
- SNMP-PROXY-MIB
- SNMP-TARGET-MIB
- SNMP-USM-MIB
- SNMP-VACM-MIB
- SNMPv2-MIB
- TCP-MIB
- UDP-MIB

Additional MIBs Supported by IPServices

- ATM-MIB
- BGP4-MIB
- CISCO-AAL5-MIB
- CISCO-ATM-EXT-MIB
- CISCO-ATM-PVC-MIB
- CISCO-ATM-PVCTRAP-EXTN-MIB
- CISCO-ATM-QOS-MIB
- CISCO-BGP4-MIB
- CISCO-CLASS-BASED-QOS-MIB
- CISCO-FRAME-RELAY-MIB
- CISCO-IETF-ATM2-PVCTRAP-MIB
- CISCO-IETF-IP-MIB
- CISCO-IETF-ISIS-MIB
- CISCO-OSPF-MIB
- CISCO-OSPF-TRAP-MIB
- CISCO-RF-MIB
- MSDP-MIB
- OSPF-MIB
- OSPF-TRAP-MIB
- RFC1315-MIB

Additional MIBs Supported by Advanced IPServices

- CISCO-BGP-POLICY-ACCOUNTING-MIB
- CISCO-IETF-IP-FORWARD-MIB
- CISCO-IPSEC-FLOW-MONITOR-MIB
- CISCO-IPSEC-MIB
- CISCO-SLB-EXT-MIB
- CISCO-SLB-MIB
- MPLS-LDP-MIB
- MPLS-LSR-MIB
- MPLS-TE-MIB
- RFC2006-MIB

Standards

IEEE 802.1s
IEEE 802.1w
IEEE 802.1x
IEEE 802.3ad
IEEE 802.3x full duplex on 10BASE-T, 100BASE-TX, and 1000BASE-T ports
IEEE 802.1D Spanning-Tree Protocol
IEEE 802.1p CoS Prioritization



Technical Specifications

IEEE 802.1Q VLAN
IEEE 802.3 10BASE-T specification
IEEE 802.3u 100BASE-TX specification
IEEE 802.3ab 1000BASE-T specification
IEEE 802.3z 1000BASE-X specification
1000BASE-SX
RMON I and II standards

Safety and Compliance

Safety Certifications

UL/CUL Recognition to UL/CSA 60950-1
TUV to EN 60950-1
CB report and certificate to IEC 60950-1 with all country deviations
CE Marking

Electromagnetic Emissions Certifications FCC Part 15 Class A

FCC Part 15 Class A
EN 55022 Class A (CISPR22 Class A)
VCCI Class A
AS/NZS 3548 Class A or AS/NZS CISPR22 Class A
MIC Class A
CE Marking

Telecommunications

CLEI Code

Environment-friendly Products and Approach

End-of-life Management and Recycling

Hewlett-Packard offers end-of-life HP product return, trade-in, and recycling programs in many geographic areas. For trade-in information, please go to <http://www.hp.com/go/green>. To recycle your product, please go to: <http://www.hp.com/go/green> or contact your nearest HP sales office. Products returned to HP will be recycled, recovered or disposed of in a responsible manner.

The EU WEEE directive (2002/95/EC) requires manufacturers to provide treatment information for each product type for use by treatment facilities. This information (product disassembly instructions) is posted on the Hewlett Packard web site at: <http://www.hp.com/go/green>. These instructions may be used by recyclers and other WEEE treatment facilities as well as HP OEM customers who integrate and re-sell HP equipment.

© Copyright 2011 Hewlett-Packard Development Company, L.P.

The information contained herein is subject to change without notice.

Cisco, CiscoWorks, and Cisco Catalyst are US registered trademarks of Cisco Systems Corporation.

Windows is a US registered trademark of Microsoft Corporation.

The only warranties for HP products and services are set forth in the express warranty statements accompanying such products and services. Nothing herein should be construed as constituting an additional warranty. HP shall not be liable for technical or editorial errors or omissions contained herein.

