

### Overview

The HP Performance-Optimized Data Center (POD) is a modular data center. The HP Performance-Optimized Data Center delivers a fast, flexible, and efficient path to data center return on investment (ROI). It can be deployed within weeks and offers an advanced power and cooling infrastructure that is more cost effective, easier to deploy and energy efficient than typical data center build-outs.

The HP POD 240a delivers best-in-class technology that can ship fully integrated and tested with IT from an HP factory in as little as 10 weeks-slashing the time for data center build-out. It offers configurations optimized for power density, enabling you to quickly upgrade or extend the capacity of your physical infrastructure.

Provisions for power and communication connections are provided. Connections to your central utility or back up power infrastructure are required. HP will provide documentation for self installations and also provide a full suite of data center and IT services from HP Critical Facilities Services and HP Technology Services.

### HP POD 240a

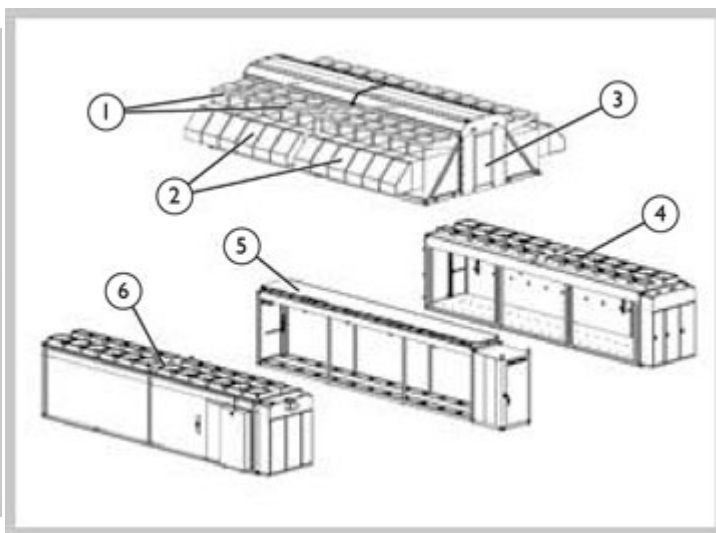
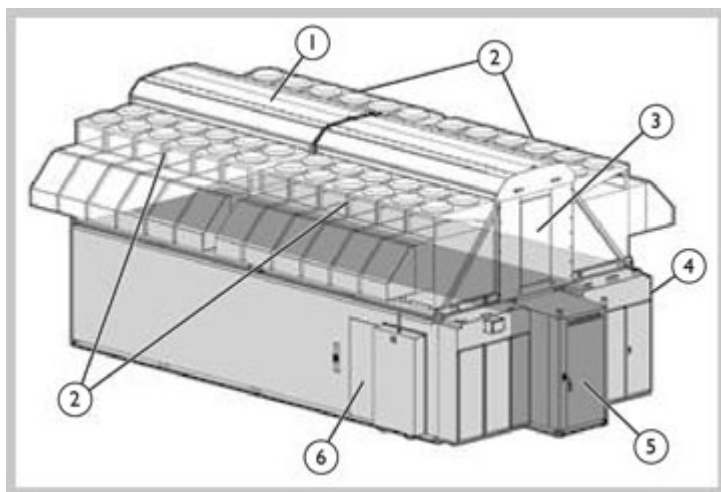

### Component View

**NOTE:** An external service area landing is located at both ends of the top of the hot aisle. Stairs will need to be added for access.

1. Hot Aisle Canopy: The canopy has two 20-ft sections, both installed atop the HP POD 240a.
2. HVAC System: Each of the four cradles contains six DX (Direct Expansion) units.
3. HVAC Service Area: The service area is directly above the hot aisle structure and is assembled at the same time as the cradle walls.
4. Secondary IT Module: The IT module houses racks, fire suppression, and humidification system. Module Adaptive Cooling System automatically optimizes cooling utilizing free air (economizer) and DX cooling supplied air overhead into the cold aisle. Hot and Cold Aisle containment is utilized to maximize capacity as well as efficiency.
5. Hot Aisle Module: The Hot Aisle module is a separate space where hot exhaust air from the servers can be expelled out of the structure or cooled and recirculated. The Hot Aisle module, when assembled to the IT modules, forms an 8' common hot aisle for easy rear rack access and serviceability.
6. Primary IT Module: The IT module houses racks, fire suppression, Environmental Control System and the POD controls cabinet. The closely coupled Adaptive Cooling System automatically optimizes cooling utilizing free air (economizer) and DX cooling supplied overhead into the cold aisle.

### Standard Features

---

#### IT Capacity

- 2,200U of available rack space, (44) 50U racks
  - Average rack densities up to 30kW , and peak racks up to 69kW
  - Offers the equivalent of 10,000 sq ft (3,048 sq m) of traditional data center space, housing over 7,000 server nodes or 24,000 hard drives
- 

#### IT Flexibility

- Racks are standard 19" universal RETMA rails
    - Supports HP and third-party industry-standard hardware with front-to-back air flow
  - Racks can be fully integrated, tested and installed through Factory Express
  - Full cable management and integrated structured cabling can be provided as part of your POD order
- 

#### Power and Cooling Capacity

- Overall POD Cooling Capacity: 1,347kW (N); 1,150 (N+1); 674kW (2N)
- Average Rack Cooling Capacity: 30kW (N); 26kW (N+1); 15kW (2N)
- CFM Capacity per Rack: 3,545 (N); 3,250 (N+1); 1,772 (2N) CFM

**NOTE:** Redundancy is per Cold Aisle module. Capacity is based on outdoor air temperature of 95°F at sea level and temperature rise through Server of 30°F.

---

#### Cooling and Energy Efficiency

- Adaptive cooling: Automatically optimized cooling based on preferences, outdoor conditions (cooling, humidity)
    - Free Air (Economizer) Mode - PUE as low as 1.05
    - DX (Close Loop) Mode
  - Close-coupled cooling and Hot/Cold Aisle containment maximize capacity and
    - Close-coupled temperature control allows use of higher air supply temperatures, which delivers improvements in energy efficiency
  - Eliminates Hot Aisle air mixing, maximizing the cold supply air which dramatically reduces the energy consumption of the HVAC system
  - Cold Air Supply is located close to the Cold Aisle, which reduces the work and power consumption the HVAC system requires to maintain Cold Aisle operating temperatures
- 

#### Standard Datacenter Building Controls

- HVAC
  - Humidity
  - Zone temperature and alarms
  - Ambient temperature
  - Control of fans
  - Air recirculation
  - Damper positioning
  - Fan fails signals and power
  - UPS status
  - EPO circuits
  - Electrical power and voltage through busways
- 



### Standard Features

#### Location and Site Provisions

- The HP POD 240a must be installed on a surface capable of supporting approximately 257,000 lbs. (116,574 kg), which will support POD weight plus IT
  - The site location for the HP POD 240a must be level +/- 0.5° tolerance
  - You must also consider clearance for installation, service, and system utilities**NOTE:** HP recommends that any surface have a local qualified Professional Engineering evaluation of site location before installation
- The POD can be located inside or outside your facility with proper ventilation
  - The HP POD is weatherized, and can be deployed as a stand-alone solution or as an extension of an existing facility
- Standard operating temperature is -20°F to 130°F (-28°C to 54°C) when operating with at least 100kW of IT load

#### Regulation and Certifications

- Listed to UL60950-1, UL50, CSA C22.2#60950-1
- Listed to UL50 and CSA C22.2#94.1; Nema Type 3R
- Classified to NFPA 70, 2008, National Electric Code

#### Serviceability

- The HP POD has a 39.5-inch (1,003.3mm) Cold Aisle and a common 8' (2.43 m) Hot Aisle, allowing IT equipment to be fully removed and serviced
  - IT serviceability is comparable to that of a traditional data center
- The POD utilizes modular cooling units that are easily serviced from the second story canopy area. HP offers a complete global portfolio of HP POD Infrastructure Services, ranging from planning to commissioning services to complete solution maintenance and management

#### Rack Information / Requirements for IT

- 19" industry standard full depth 50U racks
- 3,500 lbs (1,587kg) loading capacity
- Front to back cooling
- NOTE:** Side to side cooling, top to bottom cooling may be supported with customized solution through a custom SOW through HP Technical Services.

#### Rack PDU Info

- PDU voltage is 415V and delivers 240V, 1-phase output to the rack
- Input current monitor measure the aggregate current draw on each power circuit
- PDUs available in either 30A (17.28kW) or 60A (34.56kW) models with a variety of metered or switched C13 outlets or C19 outlets
- Up to 2 PDUs can be installed per rack
- LED digital displays report the input current of each phase or branch circuit
- IP access and security - Web interface, SSL, SSH, Telnet, SNMP, FTP, SNTP, Syslog, LDAP, LDAPS, TACACS and RS-232 Access
- Reboot a single or dual power server with one command via remote managed outlets
- Compliant to UL 60950-1
- UP-489 rated circuit breakers
- Agency approvals:
  - FCC Class A, Part 15
  - CE: EMC-EN55022 Class A, EN55024
  - EU: European Union (TUVGS mark) to EN 60950-1:2001



### Standard Features

#### HP POD Environmental control system (ECS)

- Stand-alone system designed for monitoring and controlling the HP POD environment
- Can be customized to integrate with some existing building monitor systems
- ECS monitors:
  - House panel and busway power distribution (voltage, amperage and kW load)
  - Ambient zone temperature (hot and cold aisles)
- Configuration settings:
  - Fan step setpoints
  - Fan current tolerance
  - Humidity
- Air temperature alarm points



### Optional Features

#### Fire Suppression options

- Air Sampling Smoke Detection (ASSD) system and fire alarm panel with releasing capabilities provided standard with all HP PODs.
- Manual pull stations, abort stations provided
- Horns and strobes provided to indicate alarm conditions
- Full interior fire protection provided with an appropriate number and placement of distribution nozzles
- 3M Novec 1230 fire extinguishing system provided in two canisters (main and reserve)
- Canisters are located in a NEMA 4 rated environmentally controlled cabinet or inside the POD itself depending on destination of POD and size of POD
- Capable of interfacing to site system
- IMPORTANT: Fire suppression system requires that doors to be kept shut for optimum performance

**NOTE:** The fire suppression system and agent must comply with the following codes:

- NFPA 72-National Fire Alarm Codes
- NFPA 75-Gaseous Total Flooding Extinguishing Systems
- NFPA 12A-Standard on Salton 1301 Fire Extinguishing Systems
- NFPA 12-Standard on Carbon Dioxide Extinguishing Systems
- NFPA 2001-Standard on Clean Agent Fire Extinguishing System

#### Access Control and Security Options

##### Card Reader Option

- Card reader includes 12-key pad with 125 KHz proximity and 13.56 MHz contactless smart card capability (ideal for higher security applications requiring two factor authentication - card and/or pin number)
- Meets ISO standards 14443 and 15693
- Door locks have 1600+ lb pull force magnetic locks mounted to the interior frame of the door at man entry doors and hot aisle doors
- System is capable of acting as a "node" within existing compatible infrastructures
- Status LED's shall provide information about the alarm zones, tampering, and power faults

##### System compatibility

- 13.56 MHz Smart Card Applications (Secure MIFARE, Secure ISOX, Secure ISOX Lite, DESFire)
- 13.56 MHz Smart Card CSN (CSN HID iClass, CSN Inside Picotag, others on request)
- 125 kHz Technologies (HID Prox GE/CASI Prox, AWID Prox, LenelProx)

Additional Access Control and Security System Options can be configured to your specification via a custom scope of work done by HP Technical Services.

#### Filter sensor option

Pressure sensor monitor and alarm through the HP POD ECS when the differential pressure reading indicates that filters need cleaning



### Optional Features

#### Humidifier option

Each humidifier provides 2-8 lbs/hour of water vapor into cold aisle to maintain POD environment within 20-80% relative humidity. Standard humidifier configuration includes one humidifier per IT module.

---

#### Stair to HVAC service area

Due to unique site requirements a custom stair solution will be scoped during pre-installation. **NOTE:** a custom SOW will be required, or the customer can self provide this feature.



### Service and Support

#### Service and Support

- HP Services Product support includes either 9X5 NBD or 24X7 4 hour response on site service.
- Product Warranty: POD warranty is 1 year 9X5 NBD on site support. HP Services offers uplifted support for 4 hour 24X7 response.
- HP Services offers a custom deployment service which provides the necessary installation, start-up, and commissioning services to insure a successful POD deployment.
- Other optional POD services include:
  - Tailored Factory Express for PODs
    - Build systems at the factory, integrate systems into racks, test, load integrated racks into the POD
- Onsite integration
- Custom Furnished Equipment installation/start-up
- Datacenter relocation services
- Assessments
- Capacity analysis (ensures adequate power and cooling)
- Site analysis (Mech/Elec conceptual plans and pricing to support POD)
- Site design
- Construction Documents
- Construction Administration services
- Mission-critical facilities commissioning
- Pre commissioning
- Enhanced commissioning
- Failure mode testing
- Integrated testing

**NOTE:** With the individual site requirements, most customers will be provided a customized SOW from HP Technical Services.



### Technical Specifications

| POD 240a Technical Specifications  |  |  |
|--|--|--|
| Structure  | North America  | International  |
| POD Length   | 45'  | 13.7m  |
| POD Width  | 21.5' (base), 32' (total with DX units)                                  | 6.5m (base), 9.8m (total with DX units)                                  |
| POD Height   | 21' (with DX units)  | 6.4m (with DX units)   |
| Hot and Cold Aisle Width   | (2) 39.5" Cold Aisles; (1) 8.5' Hot Aisle                                | (2) 1,003.3mm Cold Aisles; (1) 2.6m Hot Aisle                            |
| Weight (approximated with IT)  | 257,000lbs   | 116,818 Kgs  |
| Enclosure Rating   | NEMA 3R  | IP44   |
| Power  |  |  |
| Power Distribution   | (16) 200A Busways  | (16) 200A Busways  |
| POD Input Voltage  | 415V 3Ø for IT & 480V 3Ø for HVAC, 50-60Hz                               | 415V-380V 3Ø for IT and HVAC, 50-60Hz                                    |
| Rack Power Distribution*   | 30A or 60A Metered Rack Mounted Power Distribution Units                 | 30A or 60A Metered Rack Mounted Power Distribution Units                 |
| Rack Power Output Voltage  | 240V 1Ø  | 240V 1Ø  |
| PUE*   | 1.05 (Economizer Mode) to 1.4 (DX Closed Loop Mode)                      | 1.05 (Economizer Mode) to 1.4 (DX Closed Loop Mode)                      |
| *Limited to two Power Distributions Units per rack. 30A PDU Capacity is 17kW, 60A PDU Capacity is 34kW |  |  |
| * PUE is annualized and dependant on location. Measured at power entries to POD                        |  |  |
| Cooling  |  |  |
| Cooling Technology   | Adaptive Cooling: Modular Direct Expansion (DX) with Air Side Economizer | Adaptive Cooling: Modular Direct Expansion (DX) with Air Side Economizer |
| Cooling Redundancy Options*  | N; N+1; 2N   | N; N+1; 2N   |
| POD IT Capacity**  | 1,347kW (N); 1,150 (N+1); 674kW (2N)                                     | 1,347kW (N); 1,150 (N+1); 674kW (2N)                                     |
| Cooling Capacity Per Rack  | 30kW (N); 26kW (N+1); 15kW (2N)  | 30kW (N); 26kW (N+1); 15kW (2N)  |
| CFM Per Rack   | 3,545 (N); 3,250 (N+1); 1,772 (2N) CFM                                   | 3,545 (N); 3,250 (N+1); 1,772 (2N) CFM                                   |
| * Redundancy is per cold aisle module  |  |  |
| ** based on outdoor air temperature of 95°F at sea level & temp rise through Server of 30 degF.        |  |  |
| Rack Detail  |  |  |
| Rack Types   | Industry Standard 19" with RETMA Rails                                   | 482.6mm with RETMA Rails   |
| Number of racks  | 44 (19")   | 44 (482.6mm)   |
| Available U space per rack/POD   | 50U/2,200U   | 50U/2,200U   |
| Max Equipment Weight Per Rack  | 3,500 lbs  | 1,590 Kgs  |
| Support for 3rd Party Racks/IT Equipment   | Yes  | Yes  |
| Additional Technical Details   |  |  |
| Fire Supression  | Novec 1230 (Optional)  | Novec 1230 (Optional)  |
| Smoke Detection  | VESDA  | VESDA  |
| Facilities Management/Monitoring System (ECS)  | Included - PLC based with MODBUS, TCP/IP communication                   | Included - PLC based with MODBUS, TCP/IP communication                   |
| Networking Pass Throughs   | (6) 3" and (2) 1.5" Cable Portals  | (6) 76.2mm and (2) 38.1mm Cable Portals                                  |
| Networking Cable Trays   | Optional   | Optional   |



### Technical Specifications

|  |   |  |
|--|---|--|
| Networking Cable Management              | Optional  | Optional   |
| Security                                 | Key Locks Standard, additional security options available | Key Locks Standard, additional security options available      |
| Regulatory Compliance                    | NRTL "Listed" to UL60950, "Classified" to NEC, 2008-2011  | CE Compliant to IEC 60950 and International Wiring Regulations |
| <b>Environment: Operational Envelope</b> |   |  |
| Operating Temperatures                   | -20°F to 130°F  | -28.9°C to 54.4°C  |
| Operating Humidity Range                 | 0 to 100%   | 0 to 100%  |
| Operating Altitude                       | 0 to 10,000'  | 0 to 3,050m  |

| 240a (EcoPOD) PDU Options   |  |                   |                                       |                   |                                     |                                 |  |                   |
|-----------------------------|--|-------------------|---------------------------------------|-------------------|-------------------------------------|---------------------------------|--|-------------------|
| <b>Input Current Rating</b> | 30A                                    | 30A               | 60A                                   | 60A               | 30A                                 | 60A                             | 30A                                    | 30A               |
| <b>Rated Capacity</b>       | 17.28kW                                | 17.28kW           | 34.56kW                               | 34.56kW           | 17.28kW                             | 34.56kW                         | 17.28kW                                | 17.28kW           |
| <b>Input Voltage</b>        | 415V, 3Ø Y                             | 415V, 3Ø Y        | 415V, 3Ø Y                            | 415V, 3Ø Y        | 415V, 3Ø Y                          | 415V, 3Ø Y                      | 415V, 3Ø Y                             | 415V, 3Ø Y        |
| <b>Output Voltage</b>       | 240V, 1Ø                               | 240V, 1Ø          | 240V, 1Ø                              | 240V, 1Ø          | 240V, 1Ø                            | 240V, 1Ø                        | 240V, 1Ø                               | 240V, 1Ø          |
| <b>Outlet Configuration</b> | (18) C19                               | (24) C13 Switched | (24) C19                              | (36) C13 Switched | (24) C13 & (6) C13 Switched         | (24) C13 & (6) C13 Switched     | (18) C19                               | (24) C13 Switched |
| <b>Metering</b>             | Yes                                    | Yes               | Yes                                   | Yes               | Yes (SL Advanced Power Manager)     | Yes (SL Advanced Power Manager) | Yes                                    | Yes               |
| <b>Dimensions (LxWxD)</b>   | 69"x 1.75"x3.5"<br>(1,753mmx44mmx89mm) |                   | 75"x1.75"x3.5"<br>(1,905mmx44mmx89mm) |                   | 78"x1.75"x4"<br>(1,981mmx44mmx89mm) |                                 | 69"x 1.75"x3.5"<br>(1,753mmx44mmx89mm) |                   |

|             |                   |           |   |
|-------------|-------------------|-----------|---|
| <b>Rack</b> | <b>Dimensions</b> | Installed | 50U rack space<br>21.5in (54.6cm ) wide x 35.26in (89.6cm) deep x 90.4in (229.6cm) tall |
|             | <b>Weight</b>     | Operating | Net weight = 268.5lbs (122 kg)  |
|             |                   | Shipping  | Gross weight = 293.5lbs (133.4kg)   |



### Technical Specifications

#### Environment-friendly Products and Approach

#### End-of-life Management and Recycling

Hewlett-Packard offers end-of-life HP product return, trade-in, and recycling programs in many geographic areas. For trade-in information, please go to: <http://www.hp.com/go/green>. To recycle your product, please go to: <http://www.hp.com/go/green> or contact your nearest HP sales office. Products returned to HP will be recycled, recovered or disposed of in a responsible manner.

The EU WEEE directive (2002/95/EC) requires manufacturers to provide treatment information for each product type for use by treatment facilities. This information (product disassembly instructions) is posted on the Hewlett Packard web site at: <http://www.hp.com/go/green>. These instructions may be used by recyclers and other WEEE treatment facilities as well as HP OEM customers who integrate and re-sell HP equipment.

---

© Copyright 2011 Hewlett-Packard Development Company, L.P.

The information contained herein is subject to change without notice. The only warranties for HP products and services are set forth in the express warranty statements accompanying such products and services. Nothing herein should be construed as constituting an additional warranty. HP shall not be liable for technical or editorial errors or omissions contained herein.

